

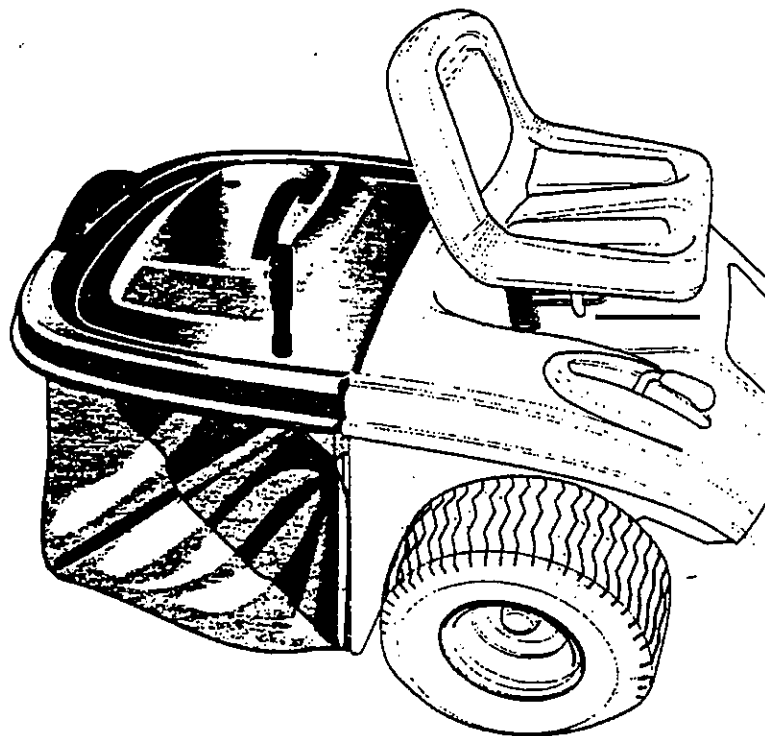

13AT516N590



J01
FORM NO. 770-1819A

13AD506N597

MTD Products Aktiengesellschaft • Saarbrücken • Germany

For Your Safety

Observe the safety and operating instructions

Before using the grass catcher attachment for the first time, read these Assembly and Operating Instructions carefully and completely. Observe all safety information while operating the unit.

Make certain that

- You are personally familiar with all relevant information.
- That all persons operating this equipment have received instructions regarding the information contained herein, and that they have understood the information.

Observe also all safety and operating instructions applying to the lawn tractor to which this grass catcher will be attached.

Safety instructions

Prior to any work on the machine

- Shut OFF the engine.
- Wait until all moving parts have come to a standstill.
- Remove the spark plug connector of the lawn tractor to prevent accidental starting of the engine.

During operation

INJURY HAZARD - Keep all personnel, and especially children, out of range of the working equipment. Keep pets leashed at a safe distance.

Safety Feature

for protection against injury and damage to property

When the mower deck is switched on, the safety interlock system is activated and automatically switches off the mower deck or the engine when

- the grass catcher is emptied
- the grass catcher is removed (e.g. for attachment of a trailer).

Proper Use of the Equipment

This equipment is designed for use

- as a grass catcher for attachment to a garden tractor
- pursuant to the instructions and safety information provided in the present Assembly and Operating Instructions.

Any use that exceeds the above restrictions must be considered improper and unsafe. The manufacturer shall not be liable for any damages resulting from improper use, the owner bears the sole risk for such operation. Unauthorised modifications made to the unit shall render null and void any liability on the part of the manufacturer for damages resulting from such modifications.

Unpacking / Assembly

Assembly

Assemble the catcher as shown in the illustrations at the front of these instructions.

Operating the Grass Catcher

Attaching the grass catcher

- Hang grass catcher onto mounting at rear of tractor and press downwards until it locks into place.

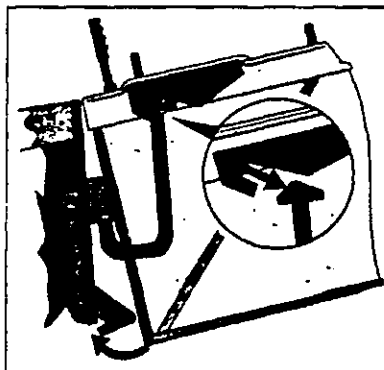

Detaching the grass catcher

- Take hold of grass catcher by both handles and lift upwards to remove.

Emptying the grass catcher

If grass clippings are left on the ground or the level monitor (optional) switches off the mower deck/engine or emits a signal.

Switch off cutting mechanism:

- Pull lever upwards out of grass catcher as far as it will go.
- Swivel lever towards front so that contents are tipped out of grass catcher.

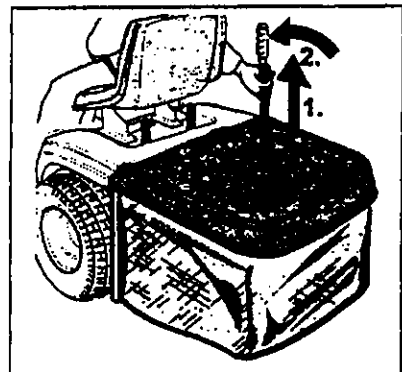

To close:

- Swivel lever towards the rear until the grass catcher attachment locks into place.
- Slowly take the lever down into the start position.

Pulling a trailer

⚠ Drive only with cutting mechanism switched off

- Remove the grass catcher from the tractor.
- Attach the trailer to the hitching device, and secure.

Cleaning

DO NOT use a high-pressure washer, because the grass catch bag could be damaged by the high-velocity water jet.

The most effective cleaning procedures are performed immediately after using the lawnmower.

- Remove and empty the grass catcher attachment.
- The grass catch bag can be cleaned with a powerful jet of water from the garden hose.

- Allow the grass catcher attachment to dry thoroughly before using it again.

Troubleshooting

Problem	Possible cause	Remedy
Clippings are not longer conveyed into the grass catch bag.	Excessive tractor driving speed.	Reduce driving speed.
	Setting for cutting height is too low.	Increase setting for cutting height.
	Grass catch bag full	Empty grass catch bag
Clippings are conveyed into the grass catch bag at a reduced volume.	Air movement is restricted due to blocking/matting of mesh fabric of grass catch bag with accumulation of clipping residue.	Remove grass catch bag, and clean (see Cleaning, above).

Pour votre sécurité

Respectez les consignes de sécurité et instructions de commande

Avant d'utiliser l'appareil pour la première fois, veuillez lire la présente notice attentivement et de bout en bout. Pendant son utilisation, respectez toutes les consignes de sécurité.

Assurez-vous

- Que vous maîtrisez bien toutes les consignes.
- Que tous les utilisateurs de l'appareil ont été informés sur ces consignes et qu'ils les ont assimilées.

Veuillez également respecter les consignes de sécurité et instructions de commande figurant dans la notice d'instruction du tracteur de pelouse contre lequel sera fixé ce bac de ramassage.

Consignes de sécurité

Avant d'effectuer tout travail sur cet appareil

- Arrêtez le moteur du tracteur de jardin.
- Attendez que toutes les pièces rotatives se soient complètement immobilisées.
- Débranchez la cosse de la bougie sur le tracteur pour empêcher tout démarrage intempestif de son moteur.

Pendant l'utilisation

Risque de blessures – Eloignez les personnes – les enfants en particulier – ainsi que les animaux de l'aire opérationnelle de l'appareil.

Dispositif de sécurité

Ce dispositif protège des blessures et des dégâts matériels.

Plateau de coupe enclenché, le système de coupure de sécurité s'active éteint automatiquement le plateau de coupe ou le moteur dans les cas suivants :

- Lorsque vous videz le bac de ramassage d'herbe.

- Lorsque vous retirez le bac de ramassage d'herbe (par ex. en mode Traction d'une remorque).

Utilisation correcte de l'appareil

Cet appareil est destiné à servir

→ de bac de ramassage l'herbe à monter contre les tracteurs de jardin

- conformément aux descriptions et consignes de sécurité données dans la présente notice d'instructions.

Toute utilisation sortant de ce cadre sera réputée non conforme.

Le fabricant décline toute responsabilité des dommages qui pourraient en résulter; le risque est à la seule charge de l'utilisateur.

Toutes modifications arbitraires de l'appareil dégagent le fabricant de toute responsabilité envers les dommages qui pourraient en résulter.

Déballage/Montage

Montage

Montez cet appareil comme le montrent les figures en début de notice.

Commande

Accrocher le bac de ramassage d'herbe

- Accrochez le bac de ramassage dans la fixation à cet effet du tracteur puis poussez le bac vers le bas jusqu'à ce qu'il encoche.

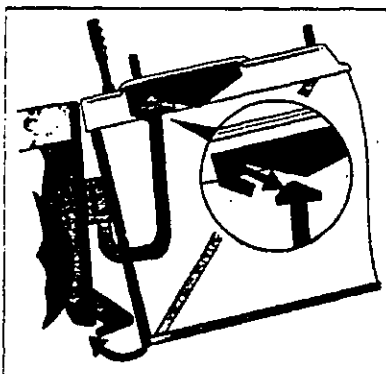

Retirer le bac de ramassage de l'herbe

- Saisissez le bac de ramassage de l'herbe par ses deux poignées et retirez-le par le haut.

Vider le bac de ramassage de l'herbe

Lorsque les végétaux coupés restent sur le sol, ou lorsque le contrôleur de niveau de remplissage (en option) éteint le plateau de coupe / le moteur, ou lorsqu'un signal sonore retentit

Pour arrêter le plateau de coupe.

- Tirez le levier vers le haut jusqu'à la butée pour le sortir du bac de ramassage de l'herbe.
- Faites pivoter le levier vers l'avant, le bac de ramassage de l'herbe bascule.

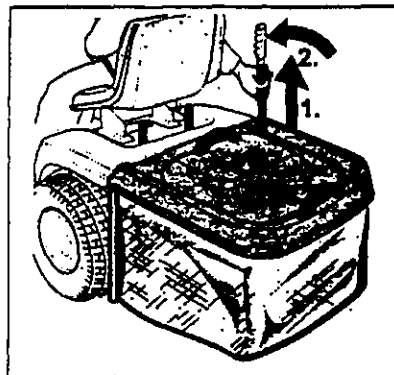

Pour fermer:

- Faites pivoter le levier vers l'arrière jusqu'à ce que le bac de ramassage d'herbe encrante.
- Abaissez le levier lentement jusqu'en position de départ.

Remorquage avec le tracteur

⚠ **Ne roulez que plateau de coupe arrêté**

- Retirez le bac de ramassage d'herbe.
- Attelez la remorque par le dispositif à cet effet puis verrouillez l'attelage.

Nettoyage

N'utilisez pas de nettoyeur haute pression car il pourrait abîmer le bac de ramassage d'herbe.

Le plus simple est de nettoyer le bac de ramassage immédiatement après la tonte.

■ Retirez le bac de ramassage d'herbe puis videz-le.

■ Vous pouvez nettoyer le sac de ramassage d'herbe à l'aide d'un jet d'eau vif provenant du flexible à eau du jardin.

■ Laisser le bac sécher à fond avant de le réutiliser.

Recherche et suppression des pannes

Incident	Cause possible	Remède
L'herbe n'est plus éjectée vers le bac.	Vitesse de roulage excessive	Réduire la vitesse de roulage.
	Hauteur de coupe trop faible	Augmenter la hauteur de tonte.
	Le sac de ramassage d'herbe est plein.	Vidanger le sac de ramassage d'herbe.
L'herbe est éjectée vers le sac en quantité insuffisante.	La toile ajourée formant le bac de ramassage est bouchée / colmatée, l'air ne peut plus s'échapper.	Retirer le bac de ramassage d'herbe puis le nettoyer (voir la section intitulée «Nettoyage»).

Ref	Order Nr	Description	Désignation	Bezeichnung	Standard	Qty
44	747-1116	Rod Handle Deck Release		Absteckbolzen		2
45	750-0566A	Spacer		Distanzstück	.26X.372X1.03lg	1
46	754-0631	V-Belt		Keilriemen		1
47	756-0487	Idler Pulley		Spannrolle		1
48	756-0627B	Idler Pulley		Spannrolle		1
49	783-04067B	Support Plate		Verstärkungsplatte		1
50	783-04077	Spring Bracket		Haltekonsole		1

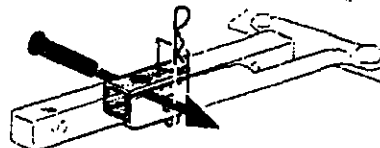
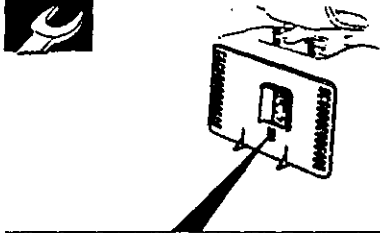
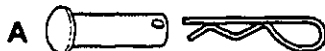
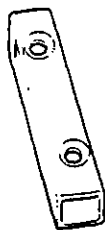
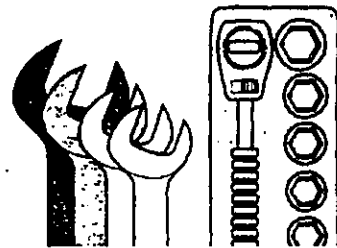
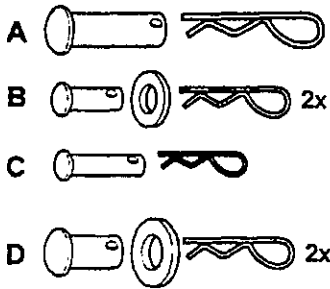
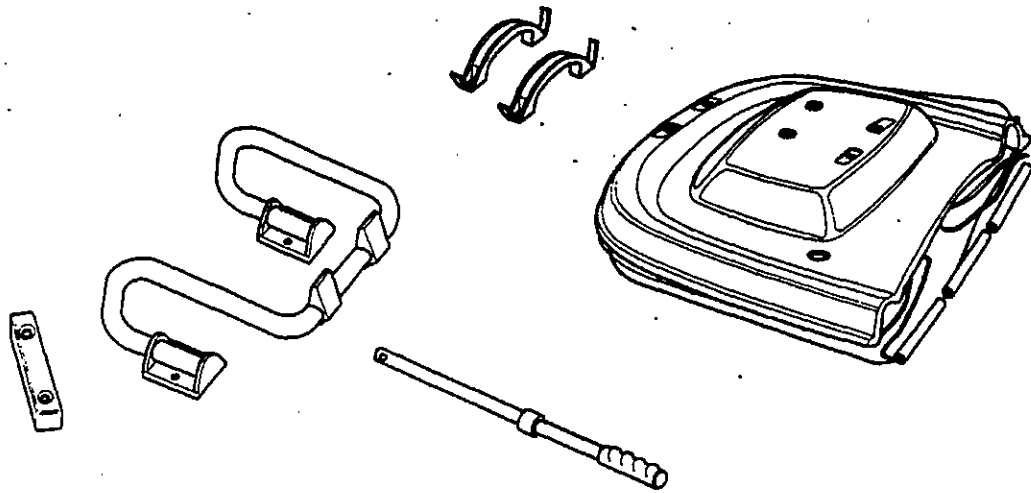

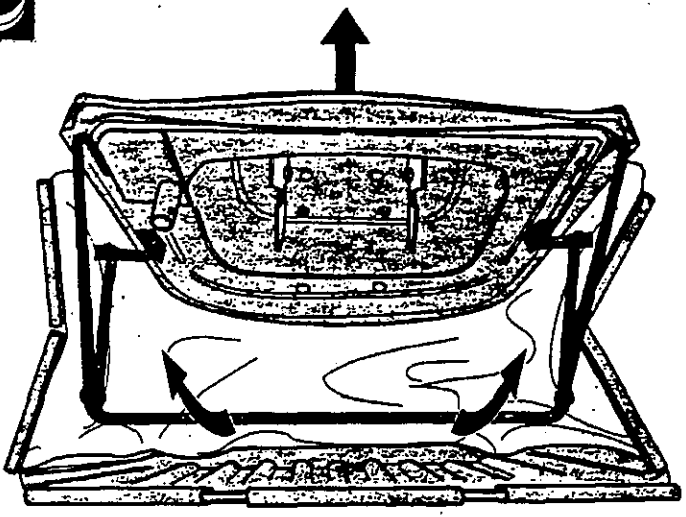
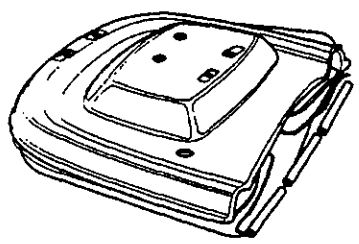
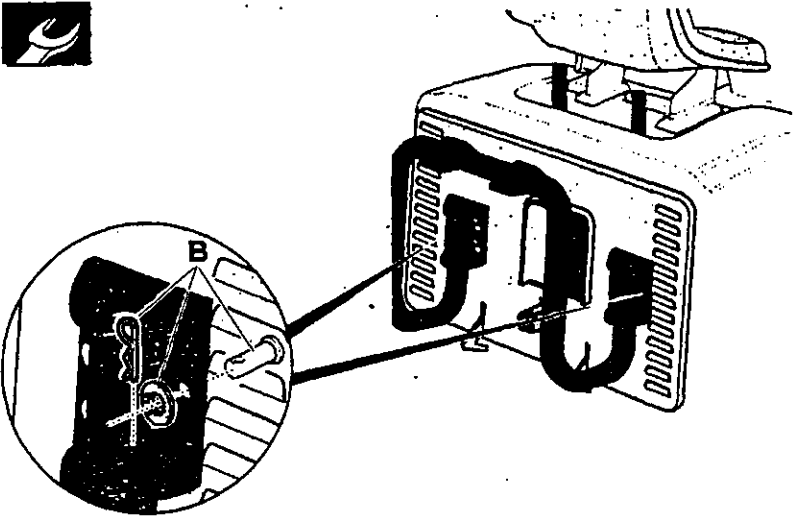
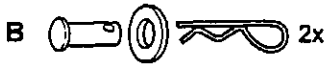
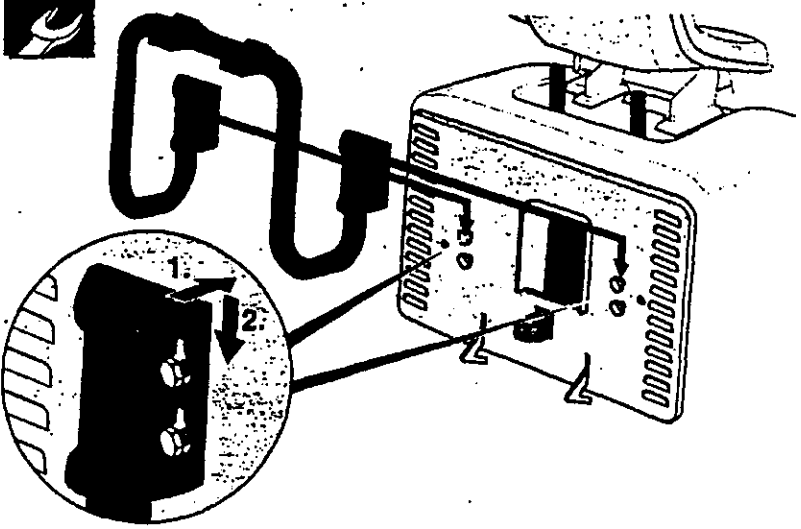
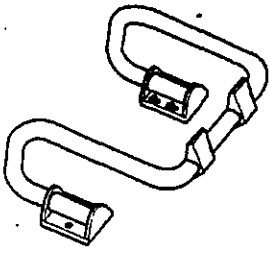

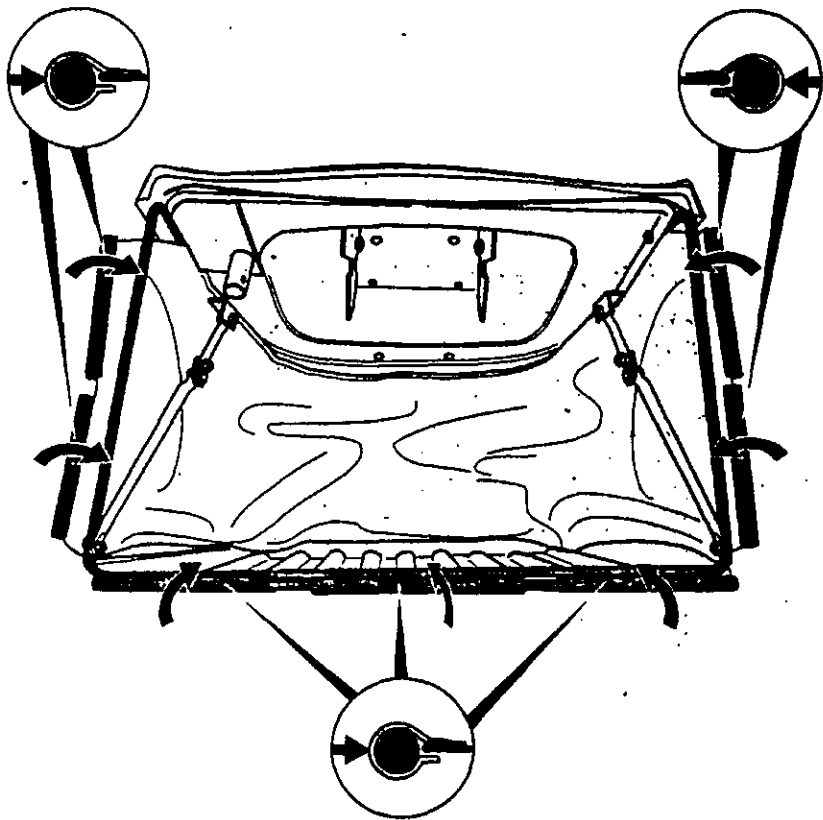
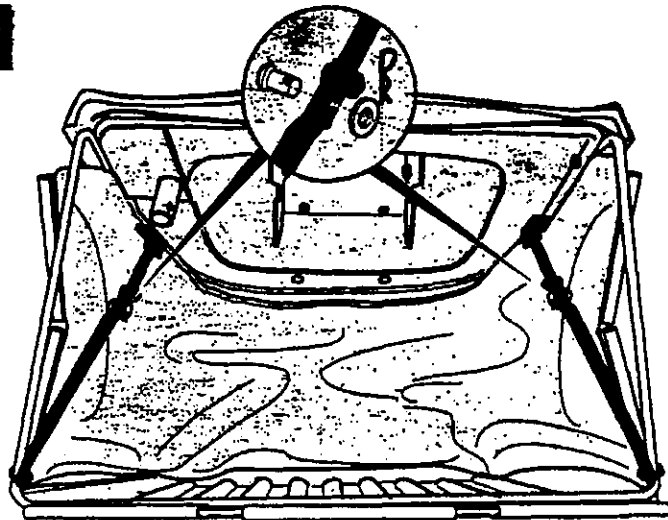

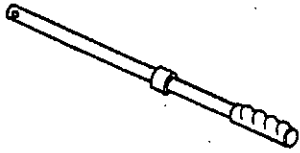

1.

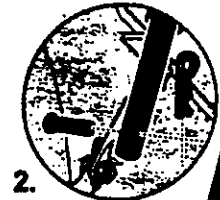
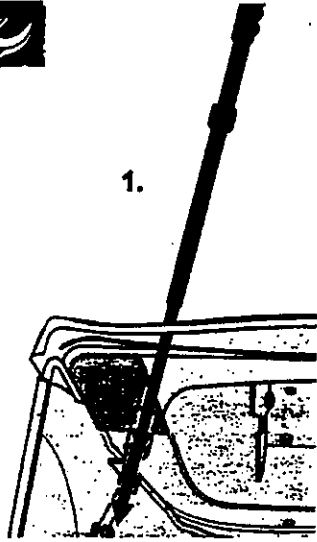

2.

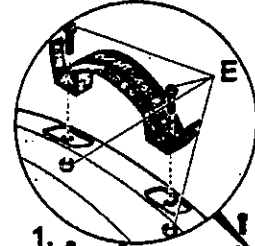
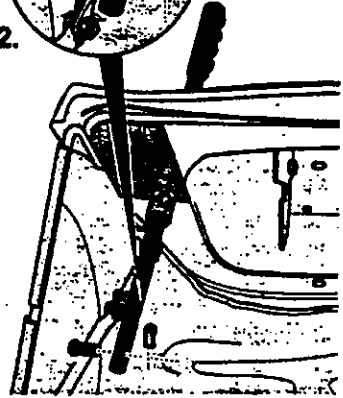

1.

1.

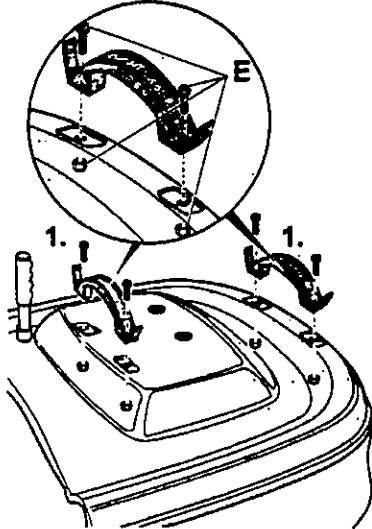

2.

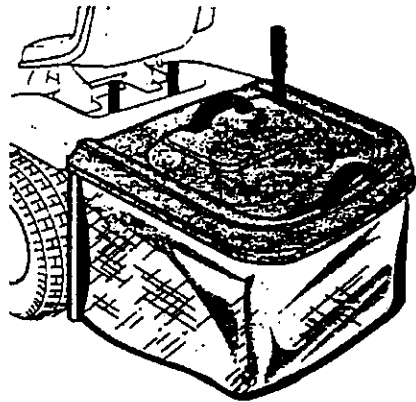
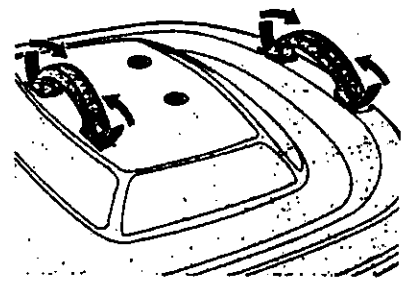

Mowing Deck 'N' 105cm/41"
 With two Idler Pulley / mit Spannrolle und Umlenkrolle

500er Serie

Ref	Order Nr	Description	Désignation	Bezeichnung	Standard	Qty
	753-04104A	Mowing Deck 'N' compl.		'N'-Deck komplett		1
1	618-04037	Spindel Assy Pulley		Messerspindel vollst.		1
2	618-0609	Spindel Assy Pulley		Messerspindel vollst.		1
3	683-04023	Idler Bracket Assy.		Konsole f. Keilriemenführung		1
4	683-04031	Deck Assy		Deck vollst.		1
5	683-0596	Brit. Assy Deck Hngr. Adj.		Halter vollst. Deckaufhäng.		1
6	710-0347	Hex Cap Screw		6-Kant Schraube	3/8-16x1.75	1
7	710-0528	Hex Cap Screw		6-Kant Schraube	5/16-18x1.25	1
8	710-0607	Screw TT		6-Kant Schraube	5/16-18x0.5	4
9	710-0778	Screw TT		6-Kant Schraube	1/4-20 x 1.50	1
10	710-1260A	Screw LD		6-Kant Schraube	5/16-18x0.750	8
11	710-1681	Hex Cap Screw		6-Kant Schraube	M8x20 DIN 933	2
12	710-3005	Hex Cap Screw		6-Kant Schraube	3/8-16x1.25	1
13	710-3103	Hex Cap Screw		6-Kant Schraube	5/16-18 x 2.00	1
14	712-0181	Jam Nut		6-kt.Sicherungsmutter	3/8-16	2
15	712-0290	Hex.Nut		6-kt.Mutter	7/16-14	1
16	712-0417A	Hex Flange Nut		6-kt.Mutter m. Flansch	5/8-18	2
17	712-0431	Hex Flange Nut		6-kt.Mutter m. Flansch	3/8-16	2
18	712-0641	Fl.Hex.Nut		6-kt.Mutter , flach	M16-1,5 DIN 936	2
19	712-0692	Jam Nut		6-kt.Sicherungsmutter	M8 DIN 985	2
20	712-3004A	Hex Flange Nut		6-kt.Mutter m. Flansch	5/16-18	1
21	712-3010	Hex.Nut		6-kt.Mutter	5/16-18	1
22	714-0470	Cotter Pin		Splint	1/8x1.25	2
23	717-1553B	Adjustment Deck Gear		Einstellrad		1
24	721-0417	O-Ring		O-Ring	16/11mm	2
25	731-04094	Cover ,Deck Belt		Keilriemenabdeckung		1
26	731-2538	Cover ,Deck Belt		Keilriemenabdeckung		1
27	731-2539	Chute Discharge Rear		Auswurfkanal hinten		1
28	732-0306	Compression Spring		Druckfeder	.406x.531x1.75	2
29	732-0459	Extension Spring		Zugfeder		1
30	734-0973	Wheel Deck		Rad Kpl. Kunststoff	5.0 x 1.38	2
31	736-0105	Bell Washer		Tellerfeder	.375x.870x.063	2
32	736-0119	Lock Washer		Federring	5/16	1
33	736-0171	Lock Washer		Federring	7/16	1
34	736-0258	Fl. Washer		Scheibe	.385x1.0x.135"	1
35	736-0300	Fl. Washer		Scheibe	.406x.875x.059"	5
36	736-0760	Lock Washer		Sicherungsscheibe	17x23,8x1.95mm	2
37	736-3050	Fl. Washer		Scheibe	.406x.812x.051	2
38	737-04003	Nozzle, Deck Water		Deckreinigungsdüse		2
38A	753-0910	Noz. Deck Water - Kit incl.18 ,24		Deckreinigungsdüse -SET incl.18 ,24	E-SET	2
39	738-0373	Shoulder Screw		Schulter Schraube	.498 Dia.x1.53"lg	2
40	738-0476	Shoulder Spacer		Schulter Schraube	.625x3.5" ,7/16	1
41	741-0591	Fig.Bearing		Flanschlager	.630x.693x.875lg	2
42	742-0670	Blade RH		Messer rechts		1
43	742-0671	Blade LH		Messer links		1

500er Serie

Mowing Deck 'N' ,105cm/41"

with one IdlerPulley only / nur mit einer Spannrolle

*ATTENTION
2 Modules*

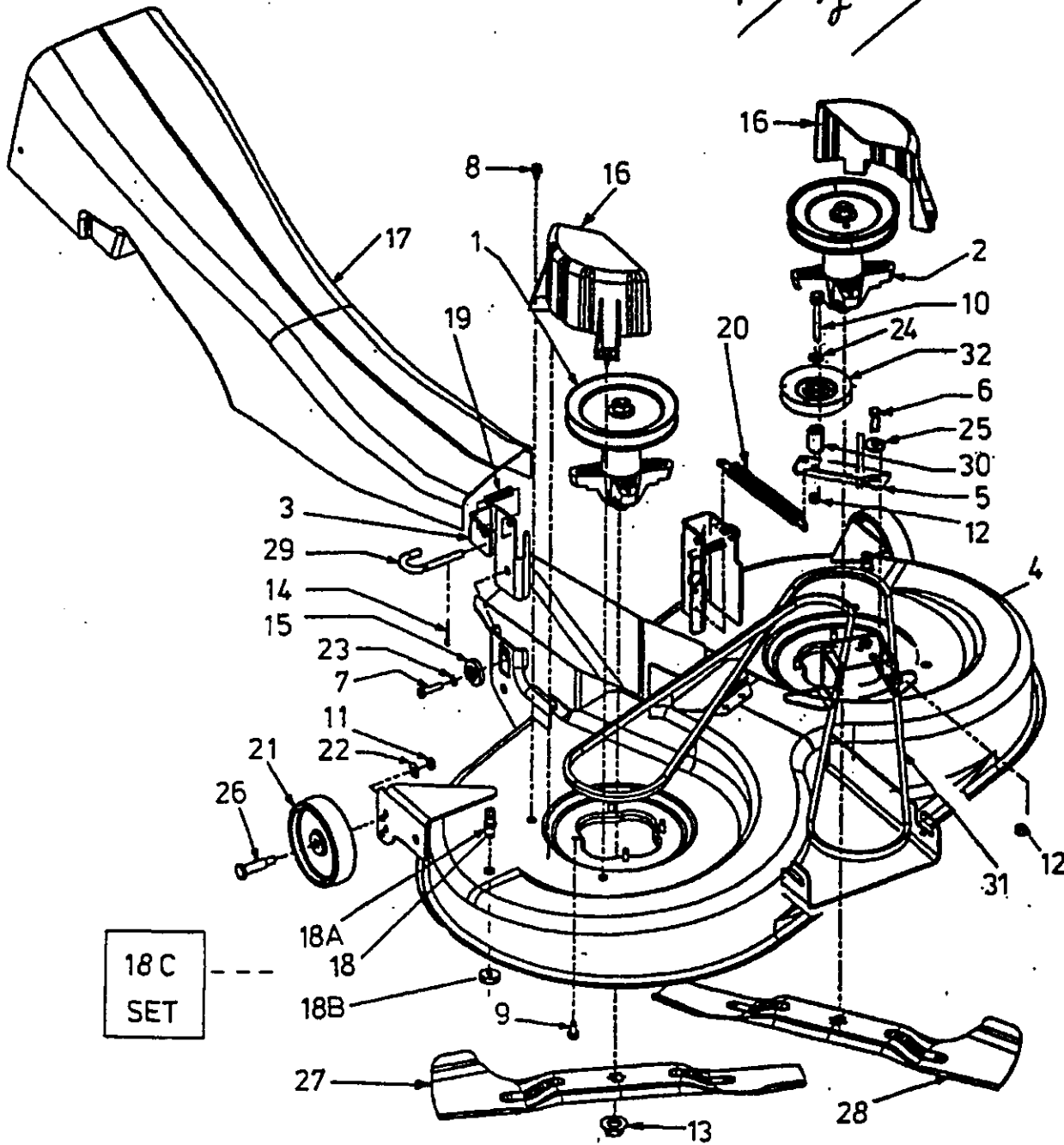

E3-01643A

500er Serie

Mowing Deck 'N' 105cm/41"

With one Idler Pulley only / nur mit einer Spannrolle

Ref	Order Nr	Description	Désignation	Bezeichnung	Standard	Qty
1	618-0609	Spindel Assy Pulley		Messerspindel vollst.		1
2	618-0610	Spindel Assy Pulley		Messerspindel vollst.		1
3	683-0596	Brkt. Assy Deck Hngr. Adj.		Halter vollst. Deckaufhäng.		1
4	683-0597	Deck Assy		Deck vollst.		1
5	683-0615	Brkt. Idler Deck		Keilriemenführung		1
6	710-0514	Hex Cap Screw		6-Kant Schraube	3/8-16x1.00	1
7	710-0528	Hex Cap Screw		6-Kant Schraube	5/16-18x1.25	1
8	710-0607	Screw TT		6-Kant Schraube	5/16-18x0.5	4
9	710-1260A	Screw LD		6-Kant Schraube	5/16-18x0.750	8
10	710-3066	Hex Cap Screw		6-Kant Schraube	3/8-16x2.75	1
11	712-0181	Jam Nut		6-kt.Sicherungsmutter	3/8-16	2
12	712-0375	Hex L-Nut		6-kt.Sicherungsmutter	3/8-16	2
13	712-0417A	Hex Flange Nut		6-kt.Mutter m. Flansch	5/8-18	2
14	714-0470	Cotter Pin		Splint	1/8x1.25	2
15	717-1553B	Adjustment Deck Gear		Einstellrad		1
16	731-2538	Cover Deck Belt		Keilriemenabdeckung		2
17	731-2539	Chute Discharge Rear		Auswurfkanal hinten		1
18	737-04003	Nozzle, Deck Water		Deckreinigungsdüse		2
18A	721-0417	O-Ring		O-Ring		2
18B	712-0641	Hex.Nut ,Fl.		Flachmutter	M16x1,5 DIN 936	2
18C	753-0910	Noz. Deck Water - Kit incl.18 ,18A,18B		Deckreinigungsdüse -SET incl.18 ,18A,18B	E-SET	2
19	732-0306	Compression Spring		Druckfeder	.406x.531x1.75	2
20	732-0594A	Extension Spring		Zugfeder		1
21	734-0973	Wheel Deck		Rad Kpl. Kunststoff		2
22	736-0105	Bell Washer		Tellerfeder	.375x.870x.063	2
23	736-0119	Lock Washer		Federring	5/16	1
24	736-3050	Fl. Washer		Scheibe	.406x.812x.051	1
25	738-0347	Shoulder Spacer		Bundscheibe	.625iDx.169OD	1
26	738-0373	Shoulder Screw		Schulter Schraube		2
27	742-0670	Blade RH		Messer rechts		1
28	742-0671	Blade LH		Messer links		1
29	747-1116	Rod Handle Deck Release		Absteckbolzen		2
30	750-1345	Spacer		Distanzstück		1
31	754-0631	V-Belt		Keilriemen		1
32	756-0487	Idler Pulley		Spannrolle		1

500er Serie

Deck Lift

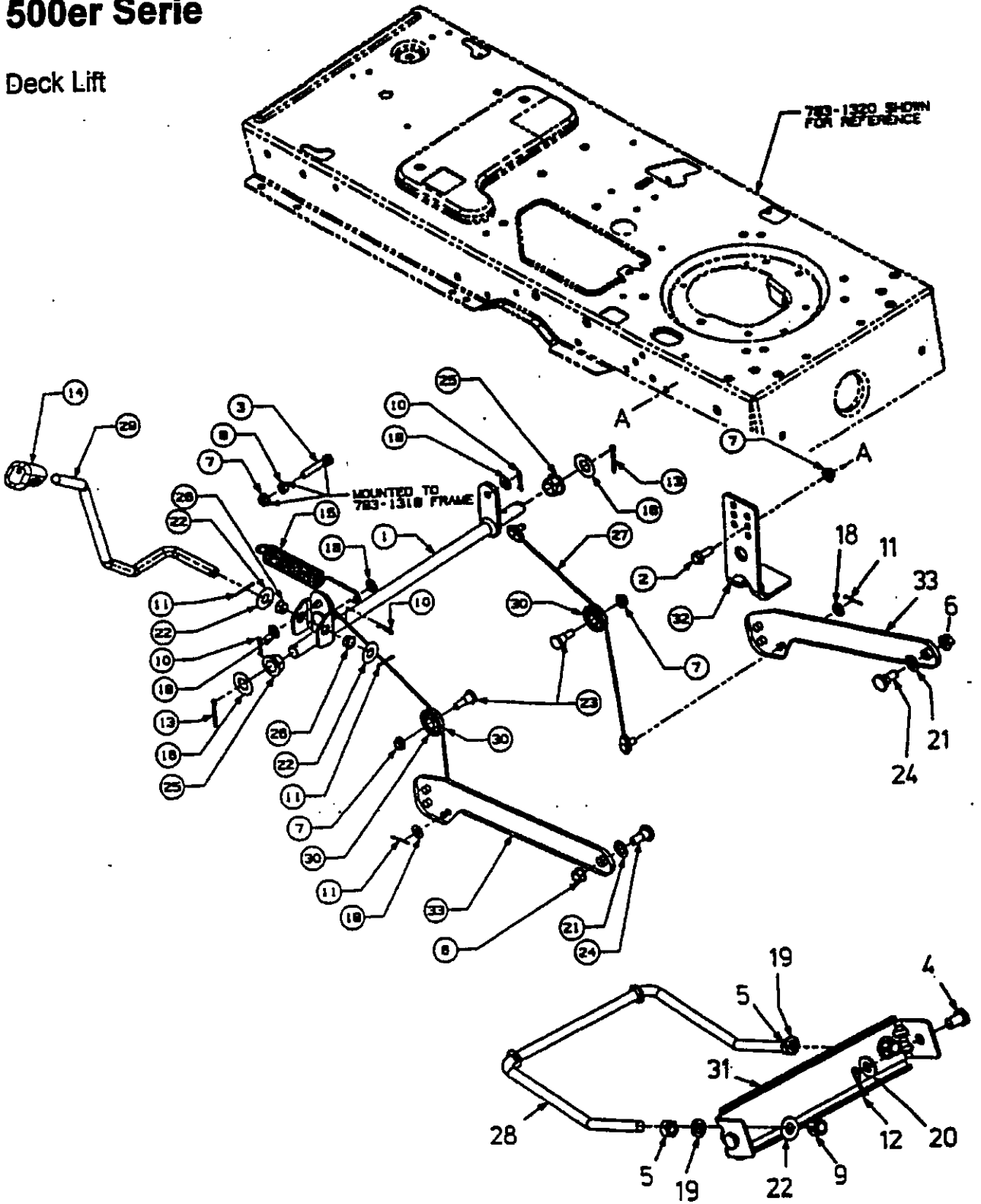

E3-01641A

500er Serie

Deck Lift

Ref	Order Nr	Description	Désignation	Bezeichnung	Standard	Qty
1	683-0587	Shf Assy Lift		Aushebungelle vollst.		1
2	710-1238	Hex Hd. Washer Screw		6-Kant Schraube	5/16-18x1.75	1
3	710-3180	Hex Bolt		6-Kant Schraube	5/16-18x1.75	1
4	711-0332	Clevis Pin		Bolzen	.50Diax.78Lg	2
5	712-0206	Hex Nut		6-kt.Mutter	1/2-13	2
6	712-0431	Flange L-Nut		Sicherungsmutter	3/8-16	2
7	712-3004A	Flange L-Nut		Sicherungsmutter	5/16-18	4
8	712-3009	Hex L-Nut		Sicherungsmutter	5/16-18	1
9	712-3083	Hex L-Nut		Sicherungsmutter	1/2-13	2
10	714-0104	Cotter Pin		Federstecker	.072Diax1.13Lg	3
11	714-0111	Cotter Pin		Federstecker	3/32x1.0	4
12	714-0145	Click Pin		Federstecker	.092x1.64Lg	2
13	714-0162	Cotter Pin		Federstecker	5/32x1.25	2
14	720-0311	Grip Handle		Handgriff	1/2"	1
15	732-0971	Extension Spring		Feder		1
16	736-0187	Fl. Washer		Scheibe	.64IDx1.24x06	2
17	736-0192	Fl. Washer		Scheibe	.631x.93x.090	2
18	736-0275	Fl. Washer		Scheibe	.344x.688x.065	5
19	736-0921	Lock Washer		Federring	1/2	2
20	736-3019	Fl. Washer		Scheibe	.631x1.062x.134	2
21	736-3068	Fl. Washer		Scheibe	1/2x.875x.060	2
22	736-3084	Fl. Washer		Scheibe	.510x1.120x.060	4
23	738-0138A	Hex Cap Screw		6-Kant Schraube	5/16-18x.620	2
24	738-0143	Shoulder Screw		Schulterschraube	3/8-16	2
25	741-0225	Hex Flange Bearing		6-Kant Flanschlager		2
26	741-0715	Bearing Snap-Flange		Flanschlager		2
27	746-1139	Cabel Lift		Kabel-Aushebung		2
28	747-1130B	Front Deck Rod Adjustm.		Verstärkungsstange Deck		1
29	747-1280	Lift Arm		Aushebearn		1
30	756-1154	Pulley Rolier		Rolle		2
31	783-0720A	Brkt. Front Deck Rod Adj.		Verstärkungsblech		1
32	783-0891B	Bracket Deck Up Stop		Höhenanschlagwinkel		1
33	783-1328	Lift Arm		Aushebearn		2

500er Serie

Hood, Grill 6-Style

Deck
777CD 30067
777CD 30068
COLUMBIA

777ED03407
777ED03408
White

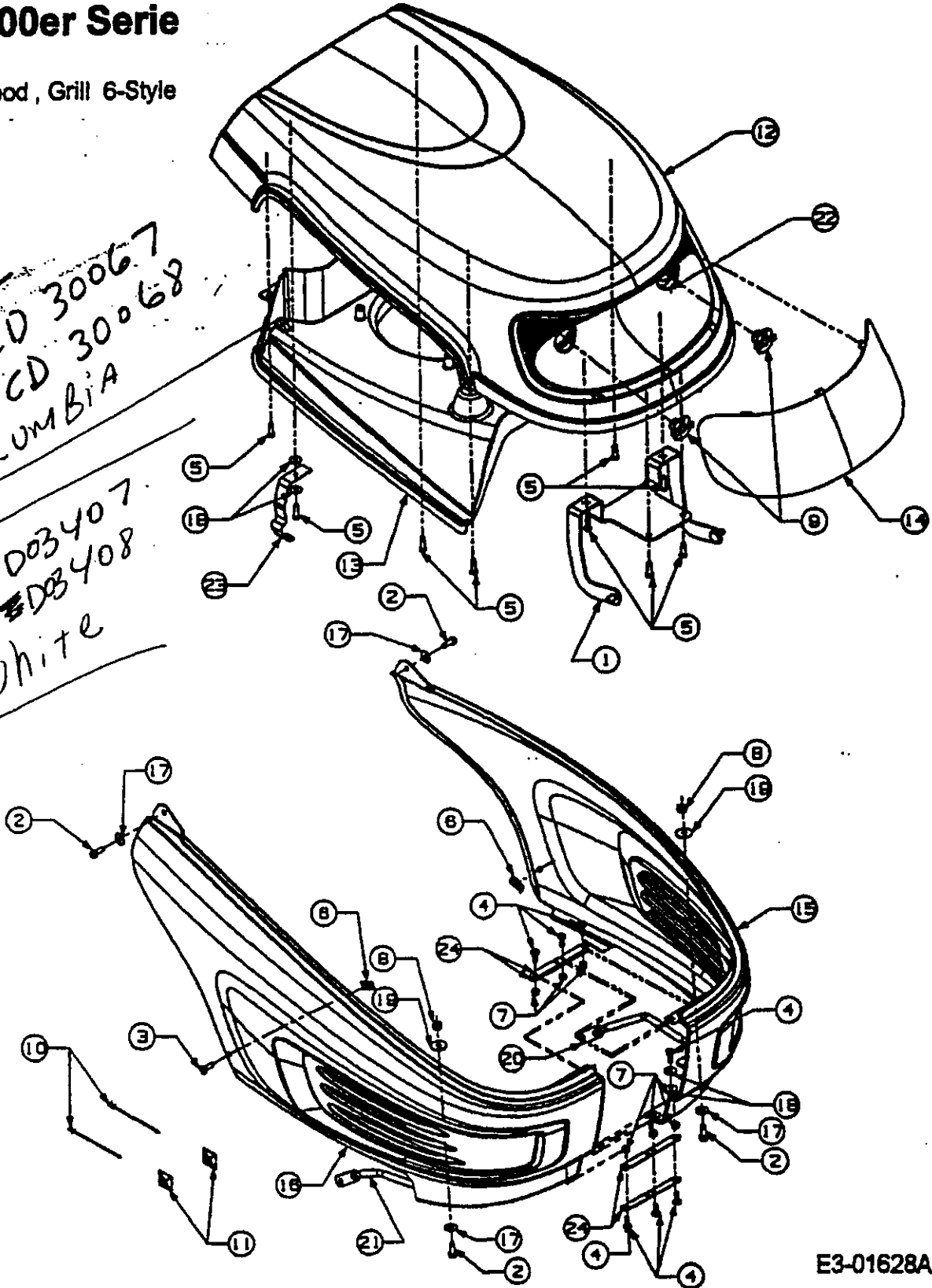

E3-01628A

500er Serie

Hood , Grill 6-Style

Ref	Order Nr	Description	Désignation	Bezeichnung	Standard	Qty
1	683-0305	Brkt. Assy Hood		Halter Haube vollst.		1
2	710-0842	Screw TT		6-Kant Schraube	1/4-20x0.750	4
3	710-0924	Screw Mech.		Fik. Schraube	1/4-20x0.750	2
4	710-1389	Screw		Linien Schraube	M6-1x16.00	7
5	710-1704	Screw Torx		Torx Schraube	M6x20	10
6	712-0292	Nut Tinn		Kaefigmutter	1/4-20	2
7	712-0633	Hex L-Nut		Sicherungsmutter	M6-1	7
8	712-0634	Hex L-Nut		Sicherungsmutter	M6-1.25	2
9	725-1649	Head Lamp Socket		Fassung	1/4	2
10	726-0197	Cable Tie		Kabelbinder		2
11	726-0359	Cabel Clamp		Kabelklemme		2
12	731-2283	Hood		Haube		1
13	731-2284	Plen		Luftverteilergehäuse		1
14	731-2286	Head Light Lens		Scheinwerferblende		1
15	731-2327A	Panel Side RH		Seitenteil rechts		1
16	731-2328A	Panel Side LH		Seitenteil links		1
17	736-0342	Fl. Washer		Scheibe	.283x.75x.030	4
18	736-0685	Fl. Washer		Scheibe	6.4x18	6
19	736-0701	Fl. Washer		Scheibe	8.4x24	2
20	747-1303	Rod		Distanzstange		1
21	747-1304	Rod		Distanzstange		1
22	777X40219	Grill Reflector		Reflektorfolie		1
23	783-0938	Latch Hood		Haubenhalter		2
24	783-1000A	Brkt. Support Grille		Befestigungsblech		4

629-0469A
Wire Short For
Light

925-0051
Bulb / socket Assy

500er Serie

Bumper Universal

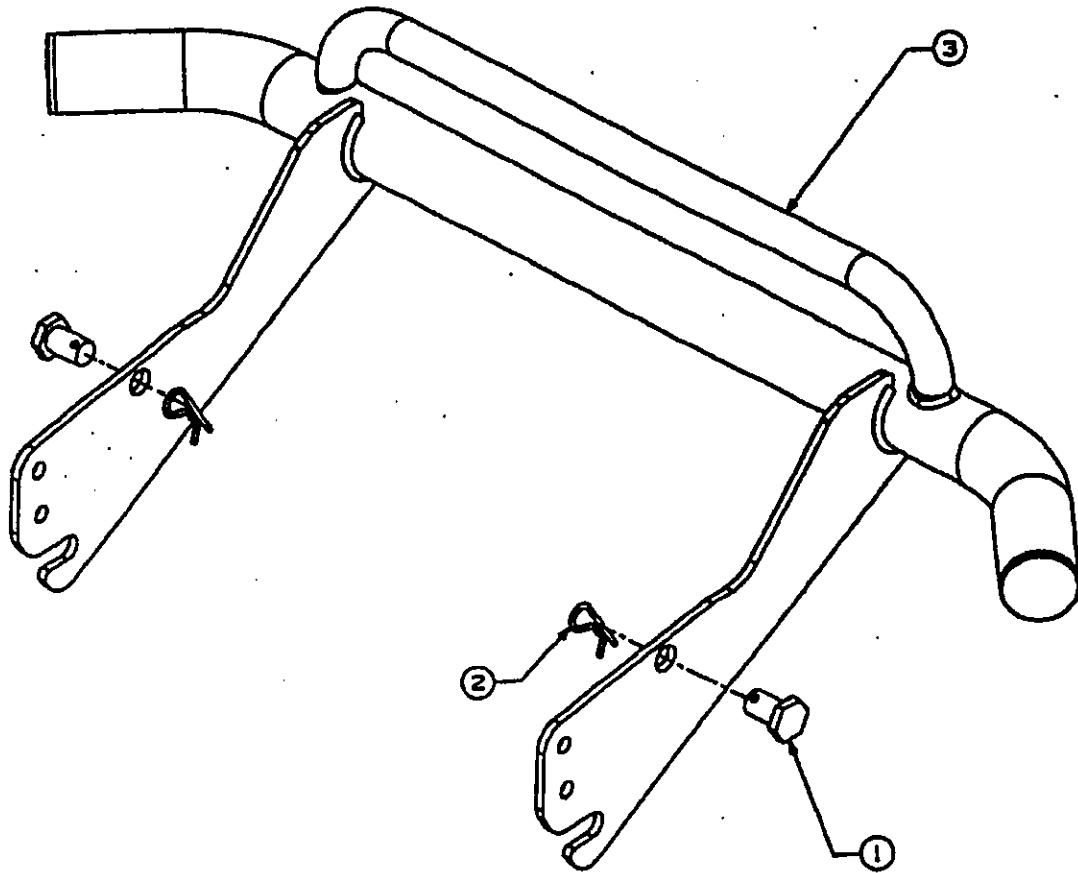

E3-01626A

500er Serie

Bumper Universal

Ref	Order Nr	Description	Désignation	Bezeichnung	Standard	Qty
1	711-0332	Clevis Pin		Bolzen	.50Diax.78Lg	2
2	714-0145	Click Pin		Federstecker	.092x1.64Lg	2
3	768-0010A	Bumper Assy Universal		Stoßstange Kpl.		1

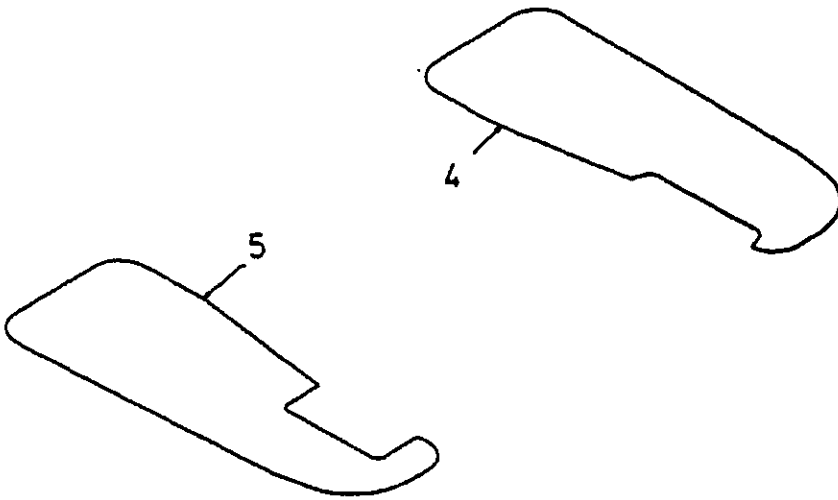
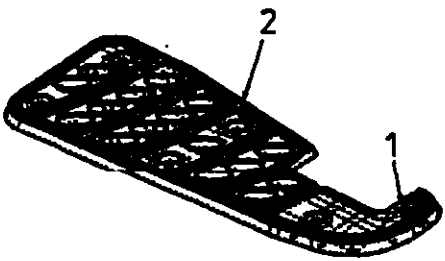

E3-01624A

500er Serie

Foot Pad
Foot Pad , Adhesive

Ref	Order Nr	Description	Désignation	Bezeichnung	Standard	Qty
1	726-3046	Foot Pad Clips		Verschlusstopfen	.250" Dia.	12
2	735-0856	Pad-Foot RH		Trittbrettauflage rechts		1
3	735-0893	Pad-Foot LH		Trittbrettauflage links		1
4	723-0492	Foot Pad Abrasive LH		Trittbrettauflage links		1
5	723-0493	Foot Pad Abrasive RH		Trittbrettauflage rechts		1

Handwritten note: 735-0857 with an arrow pointing to the description of item 3.

500er Serie

813-50028

Fender w/Box, Hydro , Rear Discharge

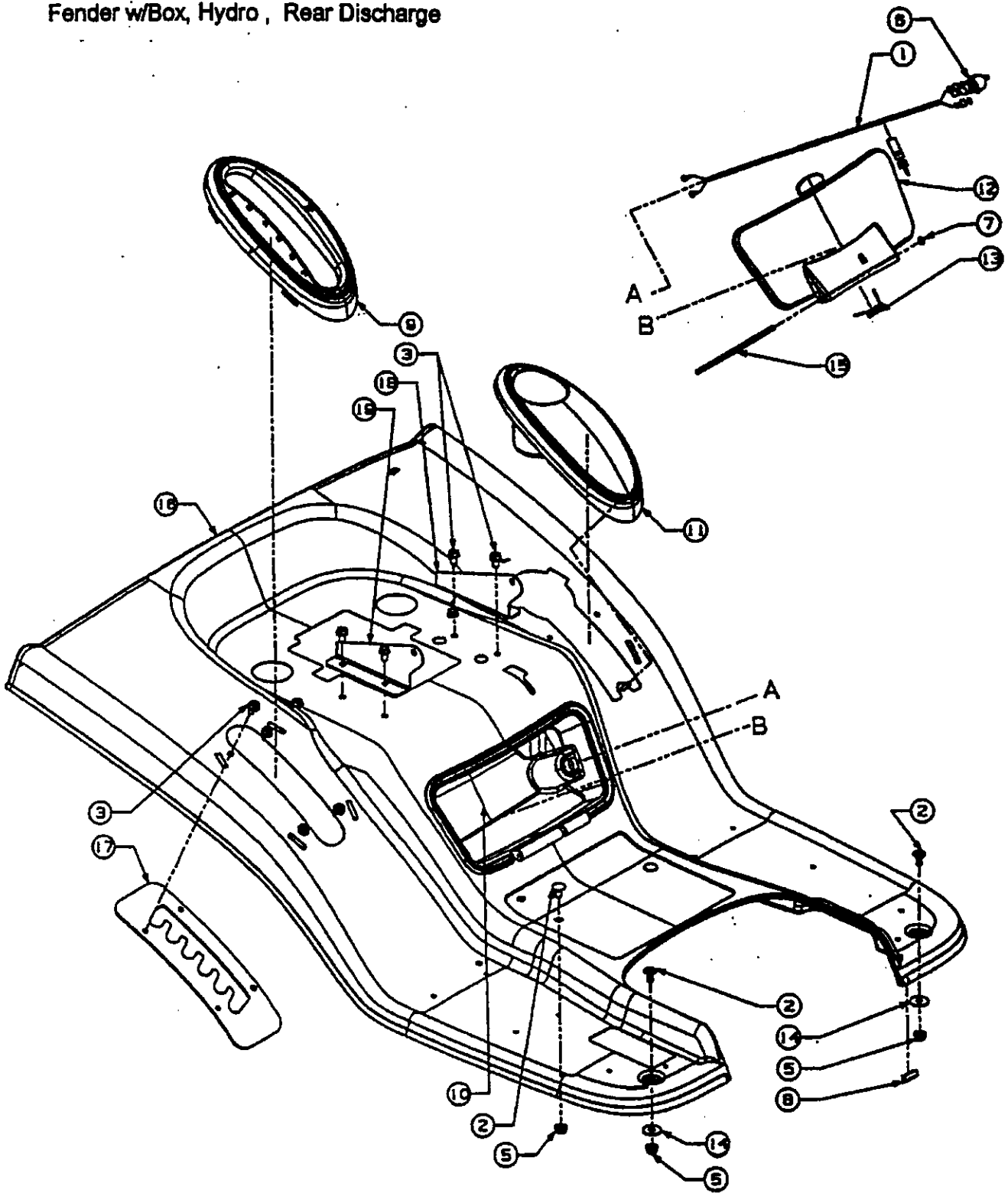

E3-01619A

500er Serie

Fender 500-Hydro ,RD w/ Box

Ref	Order Nr	Description	Désignation	Bezeichnung	Standard	Qty
1	629-1102A	Harness Assy		Kabelbaum vollst.		1
2	710-0280A	Carriage Bolt		Flachrundschräube	5/16-18x.62Lg	4
3	710-0604A	Screw TT		6-Kant Schraube	5/16-18x0.625	10
4	710-1394	Screw		Plastike Schraube Torx	M6x16	1
5	712-3004A	Flange L-Nut		Flanschmutter	5/16-18	4
6	725-2015	Electric Power Outlet		Steckdose 2-polig		1
7	726-0111	Push Cap		Kappe		1
8	731-0511	Strip Trim		Kartenschutz	1.5	1
9	731-2546	Cover Lift Lever		Abdeckung Ausrückhebel		1
10	731-2547	Tool Box		Werkzeugbox		1
11	731-2549	Cover w/Cup Holder		Abdeckung		1
12	731-2561	Cover Tool Box		Deckel f. Werkzeugbox		1
13	732-3150	Torsion Spring		Schenkelfeder		1
14	736-3078	Fl. Washer		Scheibe	.349x1.00x.063	2
15	747-1307	Rod Pivot Toolbox		Stange		1
16	783-1399	Fender		Sitzwanne		1
17	783-1404	Brkt. Lift Adjustment		Rasterplatte Ausrückhebel		1
18	783-1496	Brkt. Seat Mounting LH		Sitzhalter Links		1
19	783-1500	Brkt. Seat Mounting RH		Sitzhalter Rechts		1

500er Serie

Bag Full Indicator ,Switch

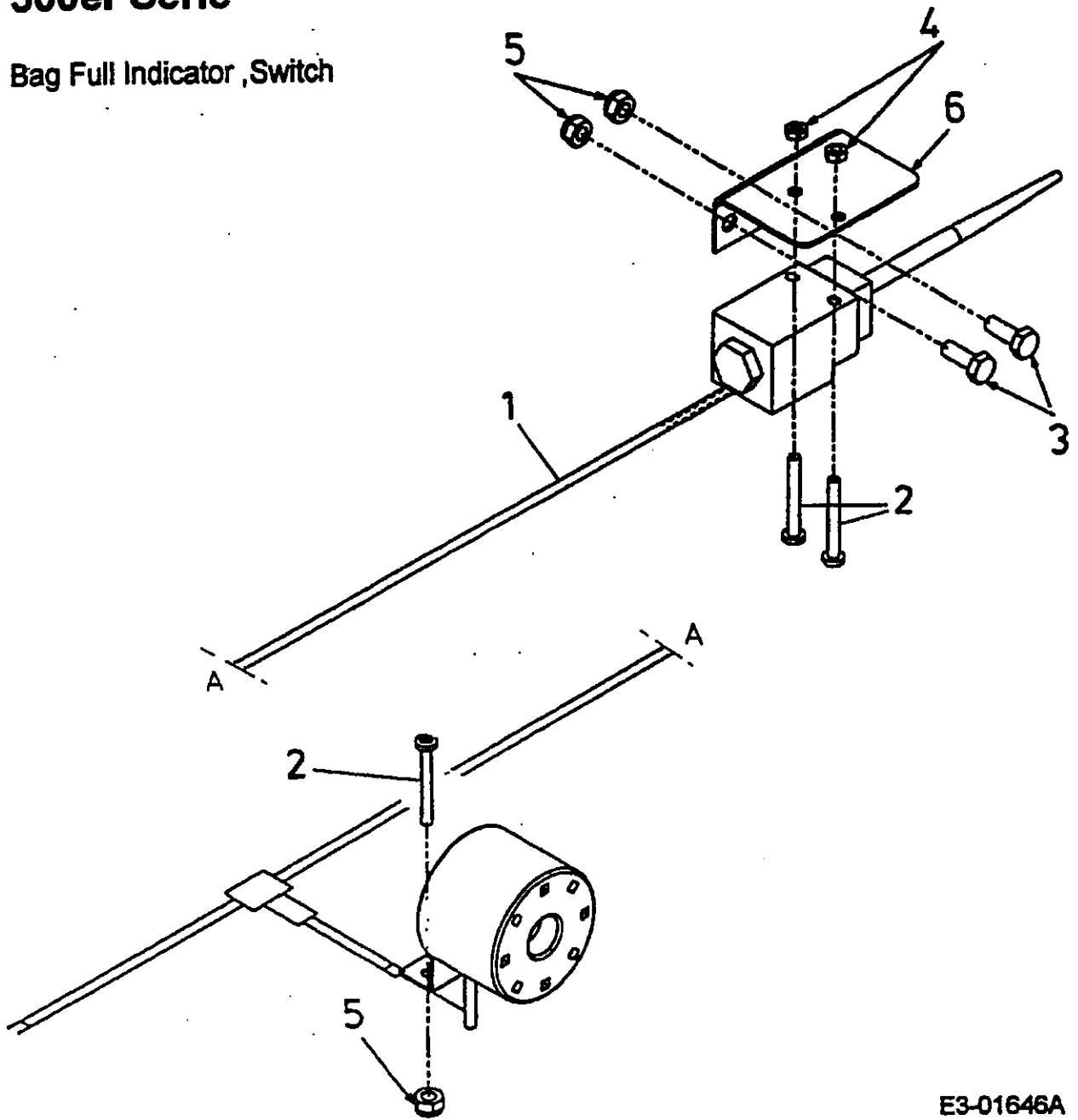

E3-01646A

500er Serie

Bag Full Indicator ,Switch

Ref	Order Nr	Description	Désignation	Bezeichnung	Standard	Qty
1	629-1089A	Harness Assy		Kabelbaum m.Füllstands- Anzeige		1
2	710-1397	Screw		Linsenschraube	M4x35 DIN 7985	4
3	710-1690	Screw		6-Kant Schraube	M6x16 DIN 933	2
4	712-0636	Hex Nut		6-kt.Mutter	M4 DIN 985	2
5	712-0891	Hex L-Nut		Sicherungsmutter	M6 DIN 985	4
6	783-0933	Brkt. Switch Bag Full		Befestigungswinkel		1

500er Serie

Grass Bag , 300 L

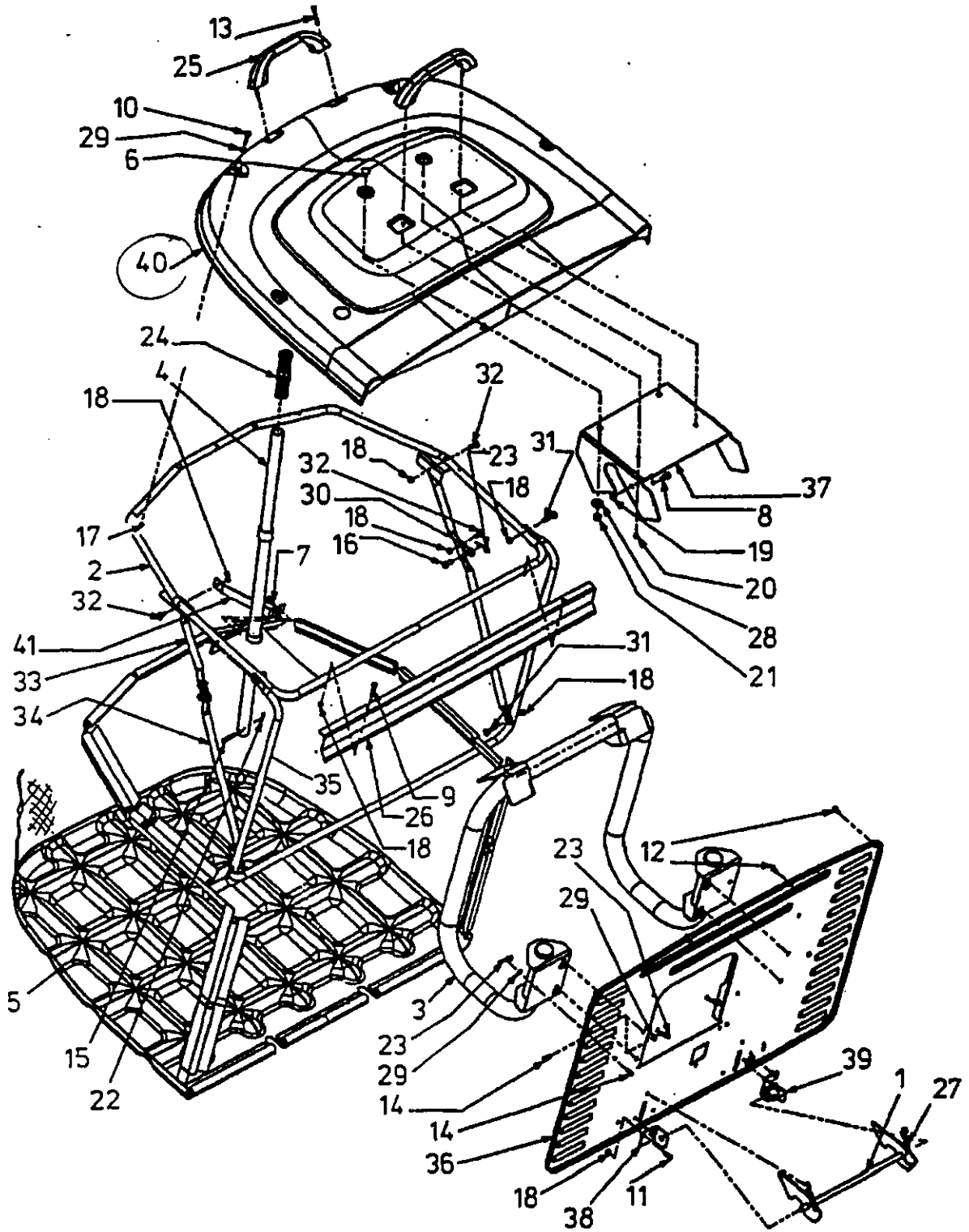

500er Serie

Grass Bag , HT 300L

Ref	Order Nr	Description	Désignation	Bezeichnung	Standard	Qty
1	647-0063	Latch Assy Bag		Sperrklinke m. Kontakthebel		1
2	649-0130	Frame Assy Top Bag		Rohrrahmen vollst. Bag		1
3	649-0132	Frame Assy Pivot		Rahmen vollst.		1
4	649-0138	Tube Assy Lever Bag		Rohr vollst.		1
5	664-0110	Bag Assy Grass		Grasfangsack vollst.		1
6	710-0280A	Carriage Bolt		Schraube	5/16-18x.62Lg	2
7	710-0607	Screw TT		6-Kant Schraube	5/16-18x0.500	2
8	710-1378	Hex Cap Screw		6-Kant Schraube	M8x16 DIN 933	2
9	710-1399	Hex Cap Screw		6-Kant Schraube	M8x25 DIN 933	2
10	710-1612	Carriage Bolt		Flachrundschrabe	M5x30 DIN 803	5
11	710-1690	Screw		6-Kant Schraube	M8x16 DIN 933	4
12	710-1387	Screw		Flachkopfschraube	M6x20	4
13	710-1755	Screw		Zylinderschraube	M5x25 DIN 912	4
14	711-0701	Clevis Pin		Bolzen	.25Diax.50	4
15	711-1017	Clevis Pin		Bolzen	.250x1.53	1
16	711-1421	Clevis Pin		Bolzen	3/8Diax.750	2
17	712-0675	Hex Nut		6-kt.Mutter	M5 DIN 985	5
18	712-0691	Hex L-Nut		Sicherungsmutter	M6 DIN 985	18
19	712-0692	Hex L-Nut		Sicherungsmutter	M8 DIN 985	2
20	712-0675	Hex Nut		6-kt.Mutter	M5 DIN 985	4
21	712-3004A	Flange L-Nut		Flanschmutter	5/16-18	2
22	714-0104	Cotter Pin		Federstecker	.072Diax1.13Lg	1
23	714-0145	Click Pin		Federstecker	.092x1.64Lg	6
24	720-0204	Grip		Griff		1
25	731-2540	Handle Bag		Griff Grasfangsack		2
26	731-2835	Extrs. Seal Bag		Dichtleiste		1
27	732-0264	Extension Spring		Zugfeder		2
28	736-0704	Fl. Washer		Scheibe	13IDx24OD	2
29	736-0730	Fl. Washer		Scheibe	7.4x14x1.6	8
30	736-3010	Fl. Washer		Scheibe	.407x.812x.135	2
31	738-1183	Shoulder Screw		Schulter Schraube	M6-1x24	4
32	738-1184	Shoulder Screw		Schulter Schraube	M6-1x12	4
33	749-1410	Tube Cross SM Bag		Querrohr		2
34	749-1411	Tube Cross LG Bag		Querrahmenträger		2
35	749-1412	Tube Frame Front Bag		Frontrahmen		1
36	783-1358	Plate End Rear Dis.		Heckplatte		1
37	783-1388	Brkt. Hook Bag		Haltehaken		1
38	783-1391	Brkt. MT Latch		Scharnierkonsole Sperrklin.		1
39	783-1392	Brkt. Latch MT Bag		Halter Deck vorn		1
40	783-1400	Cover Bag HT		Abdeckung Grasfangsack		1
41	783-1490	Brkt Support Lever		Versteifungsflasche		1

500er Serie

Axle , Pivot , Cast.

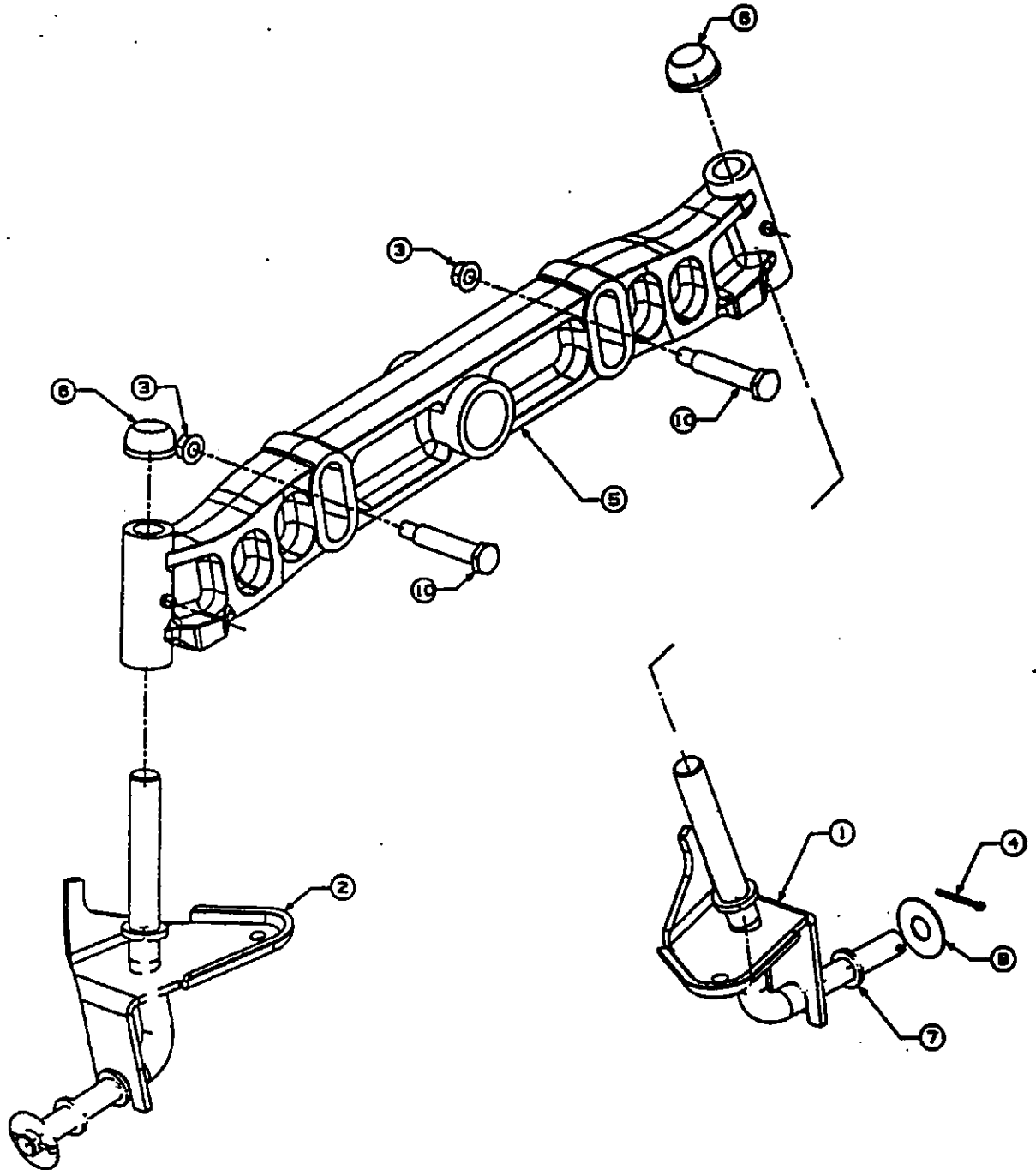

E3-01659A

500er Serie

Axle ,Pivot Cast.

Ref	Order Nr	Description	Désignation	Bezeichnung	Standard	Qty
1	638-0023	Axle Assy LH		Achse Links vollst.		1
2	638-0024	Axle Assy RH		Achse Rechts vollst.		1
3	712-0431	Flange L-Nut		Sicherungsmutter	3/8-16	2
4	714-0470	Cotter Pin		Splint	1/8x1.25	2
5	719-0525B	Axle-Cast Pivot Bar		Vorderachse Gußeisen		1
6	726-0341	Push Cap		Kappe	3/4	2
7	736-0162	Fl. Washer		Scheibe	.6411Dx1.00OD	4
8	736-0285	Fl. Washer		Scheibe	.635x1.589x.060	2
9	737-3007	Grease		Fett , 1KG	Renolit Duraplex	1
10	738-1011	Shoulder Screw		Schulter schraube		2

500er Serie

Axle , Pivot

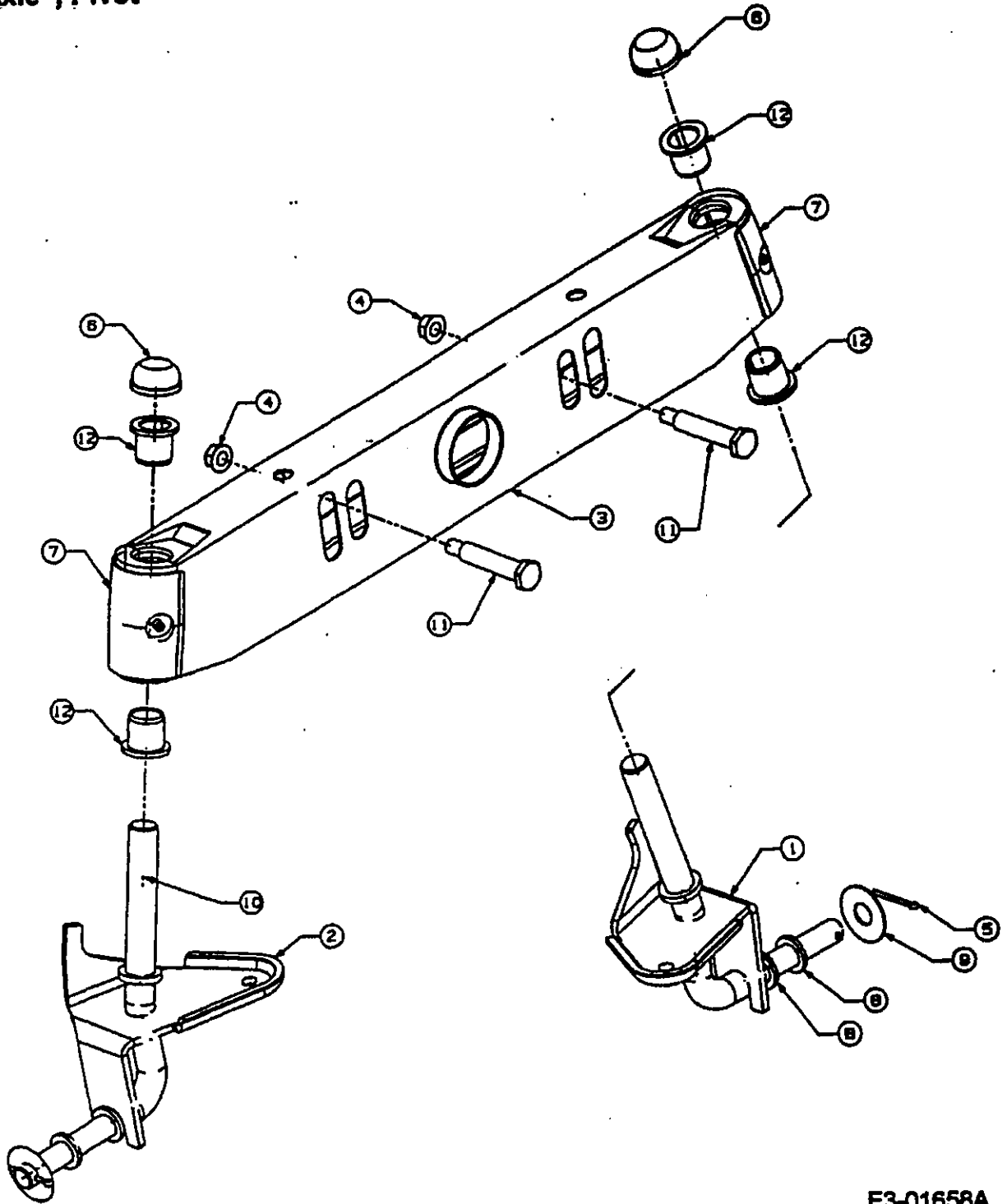

E3-01658A

500er Serie

Axle , Pivot

Ref	Order Nr	Description	Désignation	Bezeichnung	Standard	Qty
1	638-0023	Axle Assy LH		Achschenkel links vollst.	.750 Dia.	1
2	638-0024	Axle Assy RH		Achschenkel rechts vollst.	.750 Dia.	1
3	683-0128A	Axle Assy Pivot Bar		Vorderachse vollst.		1
4	712-0431	Flange L-Nut		Sicherungsmutter	3/8-18	2
5	714-0470	Cotter Pin		Splint	1/8x1.25	2
6	728-0341	Push Cap		Kappe	3/4	2
7	731-1291A	Cap End Pivot Bar		Schutzkappe		2
8	736-0162	Fl. Washer		Scheibe	.641IDx1.00D	4
9	736-0285	Fl. Washer		Scheibe	.635x1.589x.060	2
10	737-3007	Grease Alvania EP2		Fett	0.04	1
11	738-1011	Shoulder Screw		Schulterschraube	.500x2.230	2
12	741-0660	Flange Bearing		Flanschlager	.760 I.D.	4

E3-01658A

500er Serie

Pedale , Hydro w/Cruise Control
Pedale , Hydro w/o Cruise Control

--- (*)

813-60015
813-60021

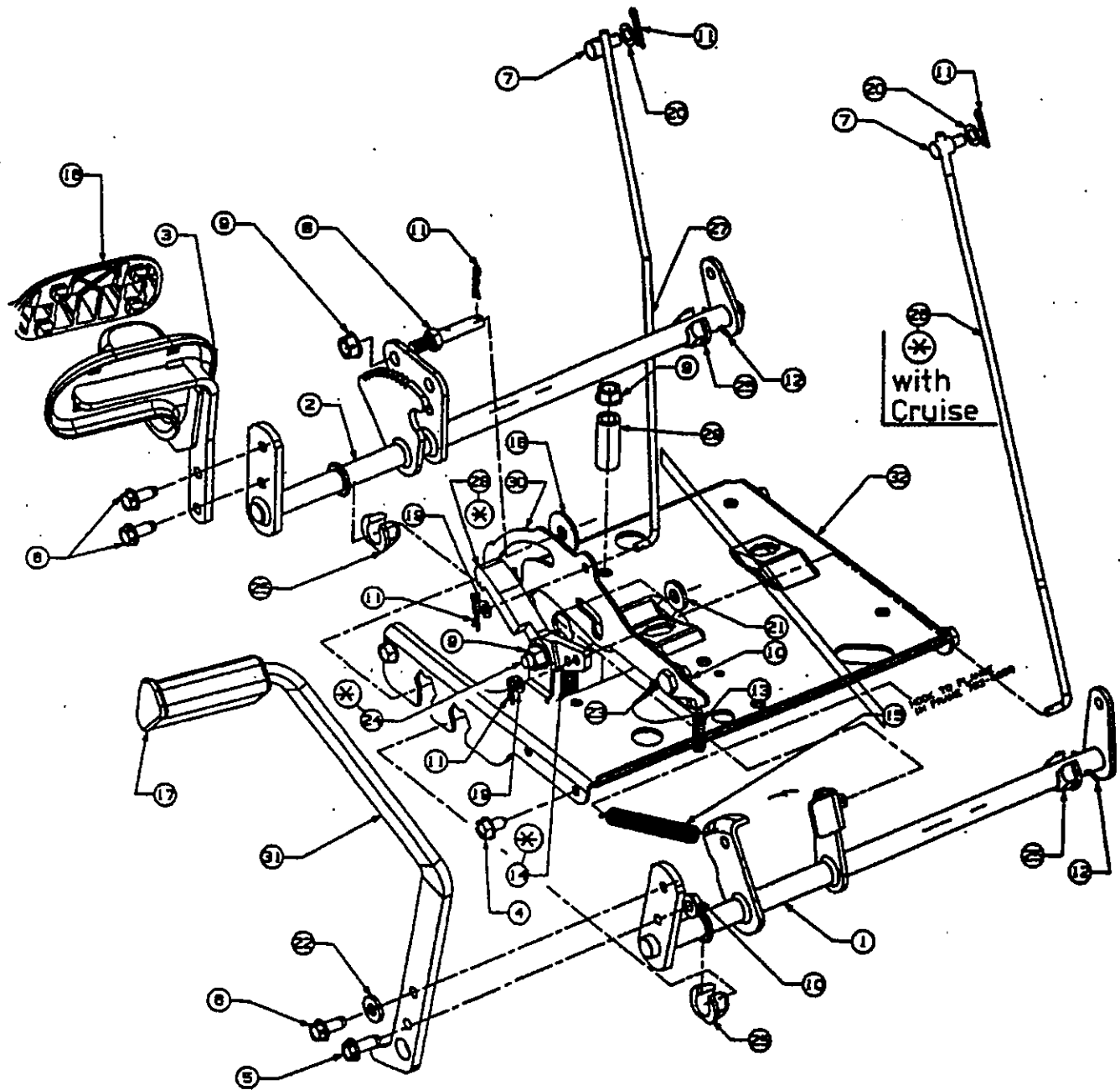

E3-01656A

500er Serie

Pedal , Hydro w/ Cruise Control
 Pedal , Hydro w/o Cruise Control

813-50015

813-50021

Ref	Order Nr	Description	Désignation	Bezeichnung	Standard	Qty
1	647-0057	Cont. Assy Brake		Bremstange vollst.		1
2	647-0082	Cont. Assy Hydro		Schaltsegment vollst.		1
3	683-0267C	Pad Assy Cont. Hydro		Pedal vollst. Hydro		1
4	710-0604A	Screw TT		6-kt. Schraube	5/16-18x0.825	4
5	710-0650	Screw TT		6-kt. Schraube	5/16-18x0.875	1
6	710-1280A	Self Tapping Screw		Schraube	5/16-18x0.750	3
7	711-0736	Adjustment Ferrule		Spindelmutter		2
8	711-1363	Pin		Stift	3/8-16x3/8x2.43	1
9	712-0431	Flange L-Nut		Sicherungsmutter	3/8-16	3
10	712-3004A	Flange L-Nut		Sicherungsmutter	5/16-18	2
11	714-0104	Cotter Pin		Federstecker	0.72Diax1.13Lg	6
12	714-0111	Cotter Pin		Federstecker	3/32x1.0	2
13	732-0335	Compression Spring		Druckfeder	.405x1.17	1
14	732-0955	Extension Spring *		Feder *	.500Dx1.41Lg	1
15	732-0963	Extension Spring		Feder	.500Diax5.37Lg	1
16	735-0662	Pad Control		Pedalauflage		1
17	735-3049	Pad Brake Control		Belag f. Fusspedal		1
18	738-0133	Flat Washer		Scheibe	.411x1.25x.100	1
19	738-0142	Flat Washer		Scheibe	.281x.50x.063	2
20	738-0204	Flat Washer		Scheibe	.344IDx.62OD	2
21	736-3004	Fl. Washer		Scheibe	.406x.875x.105	1
22	736-3008	Fl. Washer		Scheibe	.344x.750x.120	1
23	738-0155	Shoulder Screw		Schulter Schraube	.437x1.62	1
24	738-0507B	Shoulder Screw *		Schulter Schraube *	.500Diax.434	1
25	741-3065B	Hex Flange Bearing		Lager		4
26	747-1137	Rod Control Cruise *		Stange-Tempomat *		1
27	747-1138	Rod Control Brake Lock		Stange-Feststellbremse		1
28	748-0413	Latch Cruise *		Sperrklinke Tempomat *		1
29	748-0415B	Spacer		Buchse	.385x.635x1.54	1
30	783-0663C	Brkt. Lkout.		Halteplatte		1
31	783-0773	Pedal Brake		Bremspedal		1
32	783-1335	Brkt. Support Strg.		Stützkonsole Lenkung		1

Parts marked with * are val.
 for Hydro w/Cruise-
 Control
 (Ref 14 , 24 , 26 and 28)

Mit * mark. Teile sind nur
 göltig für Maschinen
 Hydro mit Tempomat
 (Ref 14 , 24 , 26 und 28)

500er Serie

Pedale , Transmatic w/Cruise --- (*)
Pedale , Transmatic w/o Cruise

813-80005
813-80022

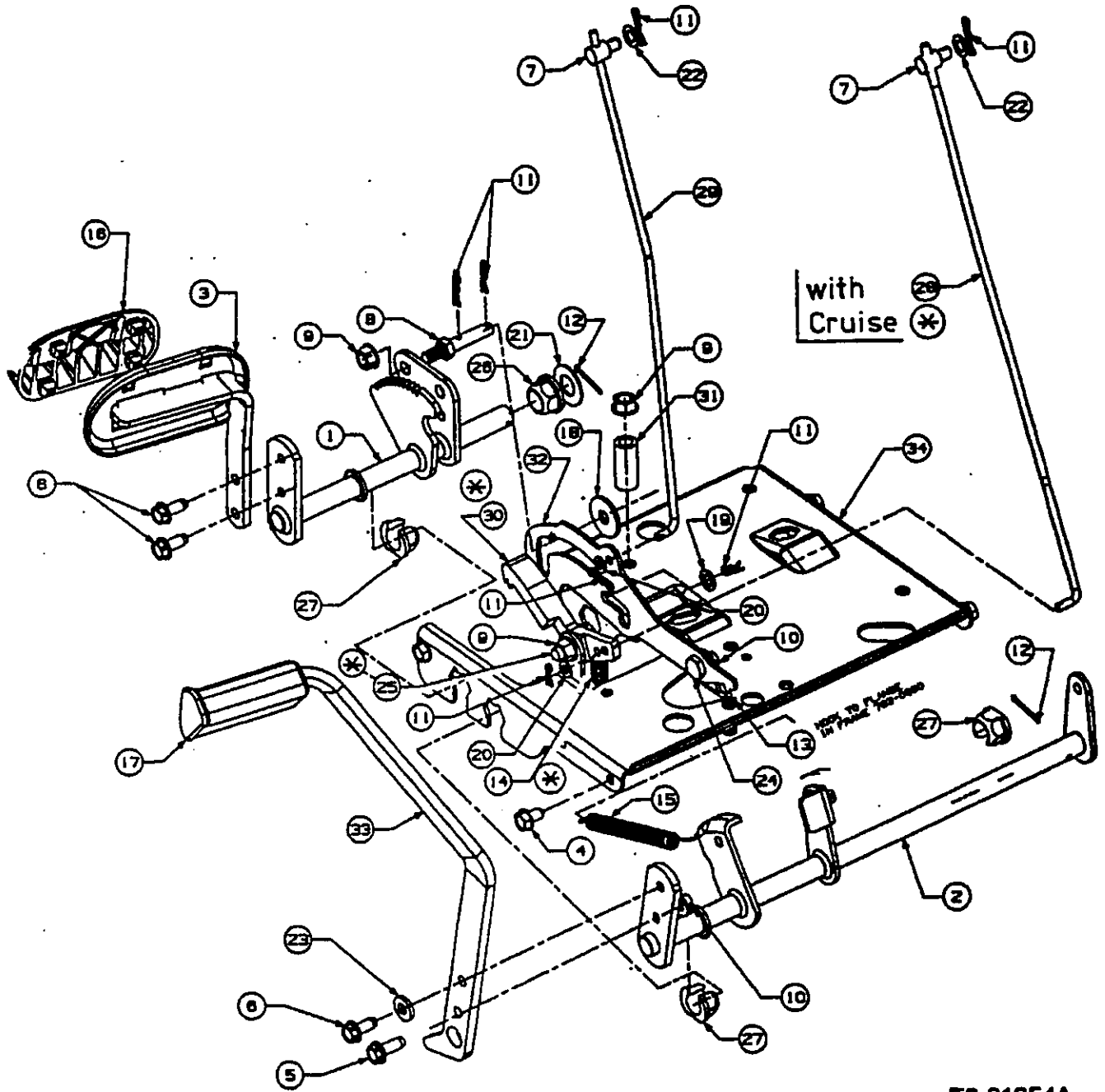

E3-01654A

500er Serie

Pedal , Transmatic w/Cruise Control
 Pedal ; Transmatic w/oCruise Control

813-80005

813-80022

Ref	Order Nr	Description	Désignation	Bezeichnung	Standard	Qty
1	647-0032	Control-Speed Assy		Welle-Variatorpedal vollst.		1
2	647-0057	Control-Brake Assy		Bremsstange vollst.		1
3	883-0266	Pedal Assy Autodrive		Pedal vollst.		1
4	710-0804A	Screw TT		6-Kant Schraube	5/16-18x0.625	4
5	710-0650	Screw TT		6-Kant Schraube	5/16-18x0.875	1
6	710-1260A	Screw LD		Schraube	5/16-18x0.750	3
7	711-0738	Adjustment Ferrule		Verbindungsstange		2
8	711-1363	Pin		Stift	3/8-16x3/8x2.43	1
9	712-0431	Flange Lock Nut		Sicherungsmutter	3/8-16	3
10	712-3004A	Flange Lock Nut		Sicherungsmutter	5/16-18	2
11	714-0104	Cotter Pin		Federstecker		7
12	714-0111	Cotter Pin		Federstecker		2
13	732-0335	Compression Spring		Druckfeder	.405x1.17	1
14	732-0955	Extension Spring *		Feder *	.50x1.41	1
15	732-0963	Extension Spring		Feder	.50x.37	1
16	735-0862	Pad Autodrive Pedal		Pedalauflege		1
17	735-3049	Pad Brake Control		Beleg für Fusspedal		1
18	736-0133	Fl. Washer		Scheibe	.411x1.25x.100	1
19	736-0140	Fl. Washer		Scheibe	.385x.82x.063	1
20	736-0142	Fl. Washer		Scheibe	.281x.50x.063	2
21	736-0187	Fl. Washer		Scheibe	.64x1.24x.06	1
22	736-0204	Fl. Washer		Scheibe	.344IDx.62OD	2
23	736-3008	Fl. Washer		Scheibe	.344x.750x.120	1
24	738-0155	Shoulder Screw		Schulter Schraube	.437x1.62	1
25	738-0507B	Shoulder Screw *		Schulter Schraube *	.500x.434	1
26	741-0225	Hex Flange Bearing		6-Kant Flanschlager		1
27	741-3065B	Hex Flange Bearing		6-Kant Flanschlager		3
28	747-1137	Rod Control Cruise *		Stange-Tempomat *		1
29	747-1138	Rod Control Brake Lock		Stange-Feststellbremse		1
30	748-0413	Latch-Cruise *		Sperrklinke Tempomat *		1
31	748-0415B	Spacer		Buchse	.385x.635x1.54	1
32	783-0732	Bracket-Lockout Transm.		Konsole Parkbremse		1
33	783-0773	Pedal Brake		Bremspedal		1
34	783-1335	Bracket Support Strg.		Stützkonsole Lenkung		1

Parts marked with * are val.
 for Transmatic w/Cruise-
 Control
 (Ref 14 , 25 , 28 and 30)

Mit * mark. Teile sind nur
 gültig für Maschinen
 Transmatic mit Tempomat
 (Ref 14 , 25 , 28 und 30)

500er Serie

Drive Hydro Long Mowing Deck N / G

attention

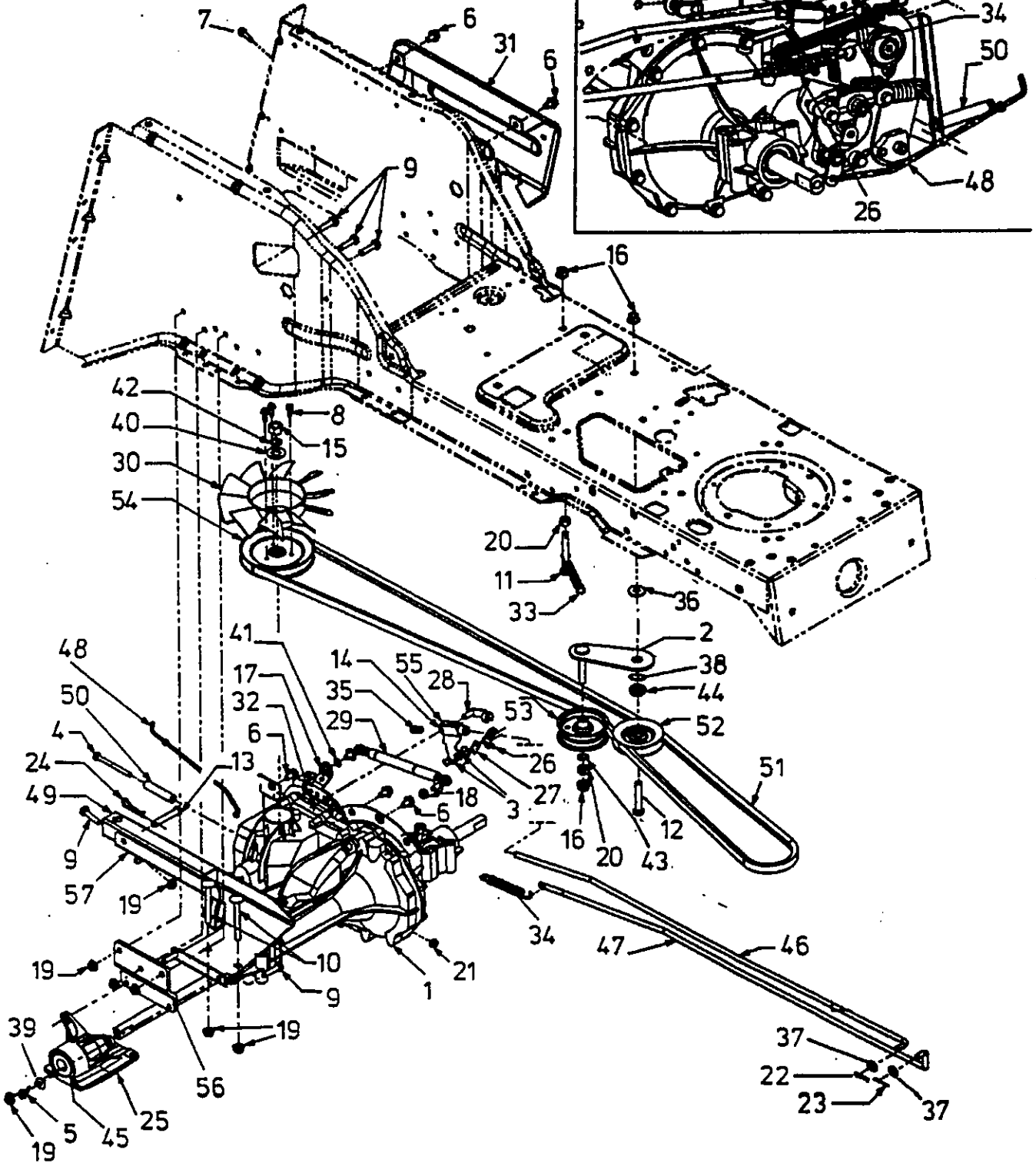

Drive , Hydro 500 - Long

(Mowing Deck 'N' / 'G')

Ref	Order Nr	Description	Désignation	Bezeichnung	Standard	Qty
1	618-0389A	Trans Assy		Getriebe vollst.		1
2	683-0804	Brkt. Assy Idler		Halter Riemenscheibe vollst.		1
3	710-0227	Screw AB		6-Kant Schraube	8-18x0.5	2
4	710-1766	Hex Cap Screw		6-Kant Schraube	M6x70 DIN 931	1
5	710-0599	Screw TT		6-Kant Schraube	1/4-20x0.5	1
6	710-0604A	Screw TT		6-Kant Schraube	5/16-18x0.625	3
6A	710-0704	Screw		6-Kant Schraube	3/8-16 x 4.00	2
7	710-0642	Screw TT		6-Kant Schraube	1/4-20x0.750	1
8	710-1189	Screw		6-Kant Schraube	12-24x0.625	3
9	710-1683	Hex Cap Screw		6-Kant Schraube	M8x30 DIN 933	8
10	710-1895	Carriage Screw		Schloßschraube	M8-1.25x75mm	2
11	710-3022	Hex Cap Screw		6-Kant Schraube	3/8-16x2.75	1
12	710-3144	Hex Cap Screw		6-Kant Schraube	3/8-16x2.00	1
13	711-0678A	Clevis Pin		Bolzen	3/8Diax2.015	1
14	711-1407	FRL		Gabelkopf		1
15	712-0333	Hex Nut		6-kt. Mutter	1/2-20	1
16	712-0431	Flange L-Nut		Sicherungsmutter	3/8-16	3
17	712-0690	Hex Nut		6-kt. Mutter	M8-1.25	1
18	712-0692	Hex L-Nut Nylon		Sicherungsmutter	M8-1.25	1
19	712-0714	Hex L-Nut		Sicherungsmutter	M8-1.25	8
20	712-3017	Hex Nut		6-kt. Mutter	3/8-16	2
21	712-0691	Hex Flange L-Nut		Sicherungsmutter	M6 DIN 985	1
22	714-0104	Cotter Pin		Federstecker	.072Diax1.13	1
23	714-0111	Cotter Pin		Federstecker	332x1.0	1
24	714-0147	Cotter Pin		Federstecker	.125x1.75	1
25	719-0534	Support Cstg.		Lagerblock		1
26	725-1773	Switch Spring Short		Schalterfeder		1
27	726-0320	Plate Insulator Nut		Isolierplatte		1
28	726-0457	Clip		ES-Bolzen	M8-32	1
29	727-0626	Cylinder Damper		Stosdämpfer Getriebe		1
30	731-1449A	Fan Blade		Lüfterflügel		1
31	731-2542	Cover Hydro		Abdeckung		1
32	732-0308	Extension Spring		Zugfeder	.50Diax6.37Lg	1
33	732-0429A	Extension Spring		Zugfeder	.50Diax3.97Lg	1
34	732-0716	Extension Spring		Zugfeder	.59ODx4.00Lg	1
35	732-0891A	Compression Spring		Druckfeder		1
36	736-0258	Flat Washer		Scheibe	.385x1.0x.135	1
37	736-0275	Flat Washer		Scheibe	.344x.688x.065	2
38	736-0773	Flat Washer		Scheibe	16x22x1 DIN988	1
39	736-0685	Flat Washer		Scheibe	6.4IDx18OD	1
40	736-0707	Flat Washer		Scheibe	15IDx28OD	1
41	736-0708	Schnorr Washer		Sicherungsscheibe	D 8	1
42	736-0751	L-Washer Schnorr		Sicherungsscheibe	13x8x1.7	1

Ref	Order Nr	Description	Désignation	Bezeichnung	Standard	Qty
43	736-0755	L-Washer Schnorr		Sicherungsscheibe	10.5x18x1.6	1
44	738-0372B	Shoulder Spacer		Distanzstück	1.00x.38x.38	1
45	741-0998	Ball Bearing		Kugellager Getriebe		1
46	747-1301	Rod Control Hydro		Schaltstange Lang Hydro		1
47	747-1302A	Rod Brake Hydro		Bremsstange		1
48	747-1315	Rod Hydro Bypass		Stange Hydro Bypass		1
49	748-0966	Tube		Vierkantrohr		1
50	750-1329	Spacer		Distanzstück	.275x.50x2.28	1
51	754-0125A	V-Belt		Keilriemen		1
52	756-0236	Pulley Idler		Riemenspannscheibe		1
53	756-3054	Pulley Idler		Spannrolle		1
54	756-1052	Pulley Trans.		Keilriemenscheibe Getriebe		1
55	783-0786	Brkt. Actr.		Brems-Kontakt-Platte		1
56	783-1371	Brkt. Mounting Hydro		Halter Hydro		1
57	783-1372	Brkt. Hitch		Anhängerkonsole Lang		1

500er Serie

Drive Transmatic Single Speed ,Long , Mowing Deck 'N' / 'G'

813-80012

Drive Transmatic Single Speed ,Short , Mowing Deck 'E'

813-80001

Ref	Order Nr	Description	Désignation	Bezeichnung	Standard	Qty
1	17840	Brkt Mounting Transaxle		Versteifungsplatte		2
2	17962	Switch Plate		Stützplatte f. Schalter		1
3	618-0580	Transmis. Ass Single Sp.		Getriebe Kpl.		1
4	631-0009A	Shift Knob		Schaltknopf		1
5A	647-0059	Lever Assy		Schaltstange	N/G-Deck	1
5B	647-0061	Lever Assy		Schaltstange	E-Deck	1
6	647-0060	Rod Assy Shift Adj.		Aushebestange		1
7	656-0002	V-Pulley		Keilriemenscheibe		1
8	656-0061	Pulley Assy		Keilriemenscheibe		1
10	683-04000	Brkt Assy Idler		Spannrollenhalter		1
11	710-0134	Carriage Screw		Fl. Rundschraube	1/4-20x.62	2
12	710-0224	Screw AB		Schraube	10x0.500	2
13	710-0227	Screw AB		6-Kant Schraube	8-16x0.500	2
14	710-0344	Hex Cap Screw		6-Kant Schraube	3/8-16x1.50	1
15	710-0642	Screw TT		6-Kant Schraube	1/4-20x0.750	4
16	710-0809	Screw TT		6-Kant Schraube	1/4-20x1.250	3
17	710-1682	Hex Cap Screw		6-Kant Schraube	M8-1.25x25.00	5
18	710-1683	Hex Cap Screw		6-Kant Schraube	M8-1.25x30.00	1
19	710-1686	Hex Cap Screw		6-Kant Schraube	M8-1.25x90.00	3
20	710-1858A	Screw TT		6-Kant Schraube	3/8-16x1.50	1
21	710-3011	Hex Cap Screw		6-Kant Schraube	3/8-16x2.25	1
22	711-0677	Ferrule - Engagment		Spindelmutter		1
23	711-0678A	Clevis Pin		Bolzen	3/8Diax2.015	1
24	711-0747	Pin		Keilriemenführung	250Diax1.68Lg	1
25	711-0993	Belt Guard Pin		Keilriemenführung		2
26	711-1171	Ferrule		Spindelmutter		1
27	712-0241	Hex Nut		6-kt.Mutter	3/8-24	1
28	712-0291	Hex L-Nut		Sicherungsmutter	1/4-20	2
29	712-0431	Flange L-Nut		Sicherungsmutter	3/8-16	4
30	712-0711	Jam Nut		6-kt.Mutter	3/8-24	2
31	712-0714	Flange L-Nut		Sicherungsmutter	M8-1.25	9
32	712-3007	Jam Nut		6-kt.Mutter	5/16-18	1
33	712-3008	Jam Nut		6-kt.Mutter	3/8-16	1
34	712-3027	Nut		Mutter	1/4-20	3
35	712-3035	Jam Nut		6-kt.Mutter	9/16-18	1
36	714-0104	Cotter Pin		Federstecker	.072Diax1.13Lg	2
37	714-0111	Cotter Pin		Splint	3/32x1.0	1
38	714-0147	Cotter Pin		Federstecker	.125x1.75	1
39	714-0149B	Internal Cotter Pin		Federstecker	1/2	1
40	714-0470	Cotter Pin		Splint	1/8x1.25	1
41	723-3018	Ball Joint		Kugelgelenk		1
42	725-1773	Switch Spring Short		Schalter-Feder		1
43	726-0320	Plate Insulator Nut		Isolierplatte		1

Ref	Order Nr	Description	Désignation	Bezeichnung	Standard	Qty
44	726-0353	Push Nut		Achsen-Klemmring		2
45	732-0525	Clip Spring Compression		Feder		1
46	732-0718	Spring Extension		Zugfeder	.590Dx4.00Lg	1
47	732-0863	Spring Extension		Zugfeder	.50Diax6.37Lg	1
48	732-1030	Torsion Spring		Zugfeder rechts		1
49	736-0159	Washer		Scheibe	.349x.876x.063	1
50	736-0169	Lock Washer		Federring	3/8	1
51	736-0272	Fl. Washer		Scheibe	.510x1.00x.060	1
52	736-0275	Fl. Washer		Scheibe	.344x.688x.065	1
53	736-0425	Bell Washer		Tellerfeder	.325x.930x.045	1
54	736-0427	Bell Washer		Tellerfeder	.567x1.125x.06	1
55	736-3010	Fl. Washer		Scheibe	.407x.812x.135	1
56	736-3052	Fl. Washer		Scheibe	.406x1.00x.105	1
57	736-3078	Fl. Washer		Scheibe	.349x1.00x.063	2
58	736-3081	Fl. Washer		Scheibe	.320x.600x.060	1
59	736-0347	Shoulder Spacer		Bundscheibe	.625x.189	1
60	738-0372B	Shoulder Spacer		Distanzstück	1.00x.38x.38	1
61	747-1127	Rod Adj. Idler		Verbindungsstange		1
62A	747-1298A	Rod Brake ,long		Bremsstange lang	N/G-Deck	1
62B	747-1295A	Rod Brake ,short		Bremsstange kurz	E-Deck	1
63	748-0331	Shoulder Spacer		Shft-Hölse	.625Diax3.24Dia	1
64	748-0334	Spacer T-Axe		Distanzhölse		1
65	749-0986	Tube		Vierkanrohr		1
66	750-0566	Spacer		Hölse		3
67	750-1311	Spacer		Distanzstück	17x9x62 (mm)	1
68	754-0626	V-Belt , 68.10"	5LK680	Keilriemen , 68.10"		1
69A	754-0629	V-Belt , 53.03"		Keilriemen , 53.03"	N/G-Deck	1
69B	754-0499	V-Belt , 47.60"		Keilriemen , 47.60"	E-Deck	1
70	756-0236	Pulley Idler		Riemenspannscheibe		1
71	756-3054	Pulley Idler		Spannrolle		3
72	736-0256	Fl. Washer		Scheibe	.635x.930x.033	1
73	783-1323	Brkt. Idler		Halter Riemenscheibe		1
74	783-1361	Brkt. Shift		Schalthebel Konsole		1
75	783-1362	Support Lever Shift		Träger Schalthebel		1
76A	783-1369	Brkt. Hitch GT		Anhängerkonsole Kurz	N/G-Deck	1
76B	783-1359	Brkt. Hitch		Anhängerkonsole Lang	E-Deck	1
77A	783-1387	Brkt. Rod Shift		Halter Aushebestange	N/G-Deck	1
77B	783-1432	Brkt. Rod Shift		Halter Aushebestange	E-Deck	1

500er Serie

Drive , Transmatic Single Speed , Long , Mowing Deck N / G

Drive , Transmatic Single Speed , Short , Mowing Deck 'E'

attention
PAS DE DECKE
CHEZ KUI

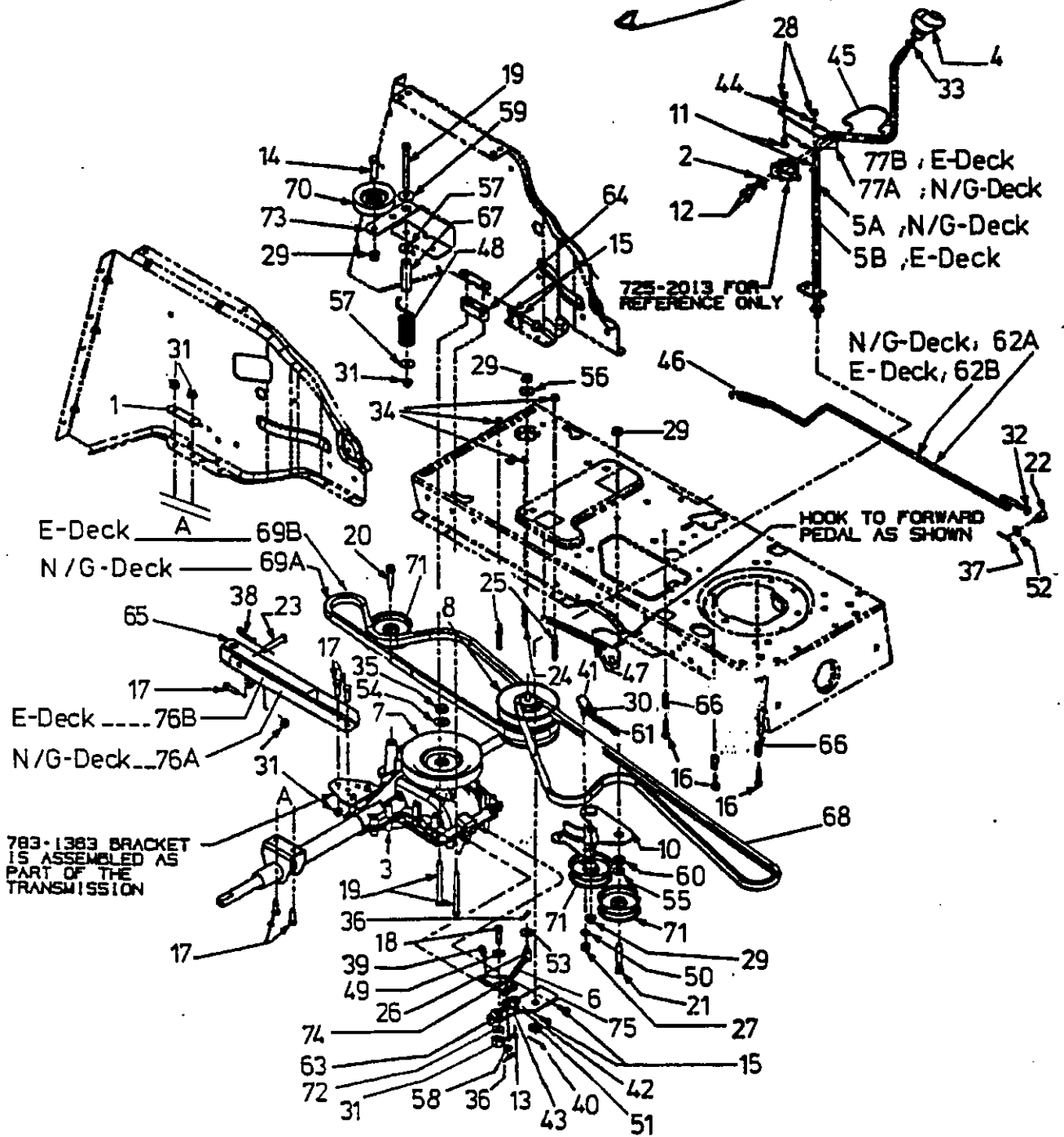

E3-01650A

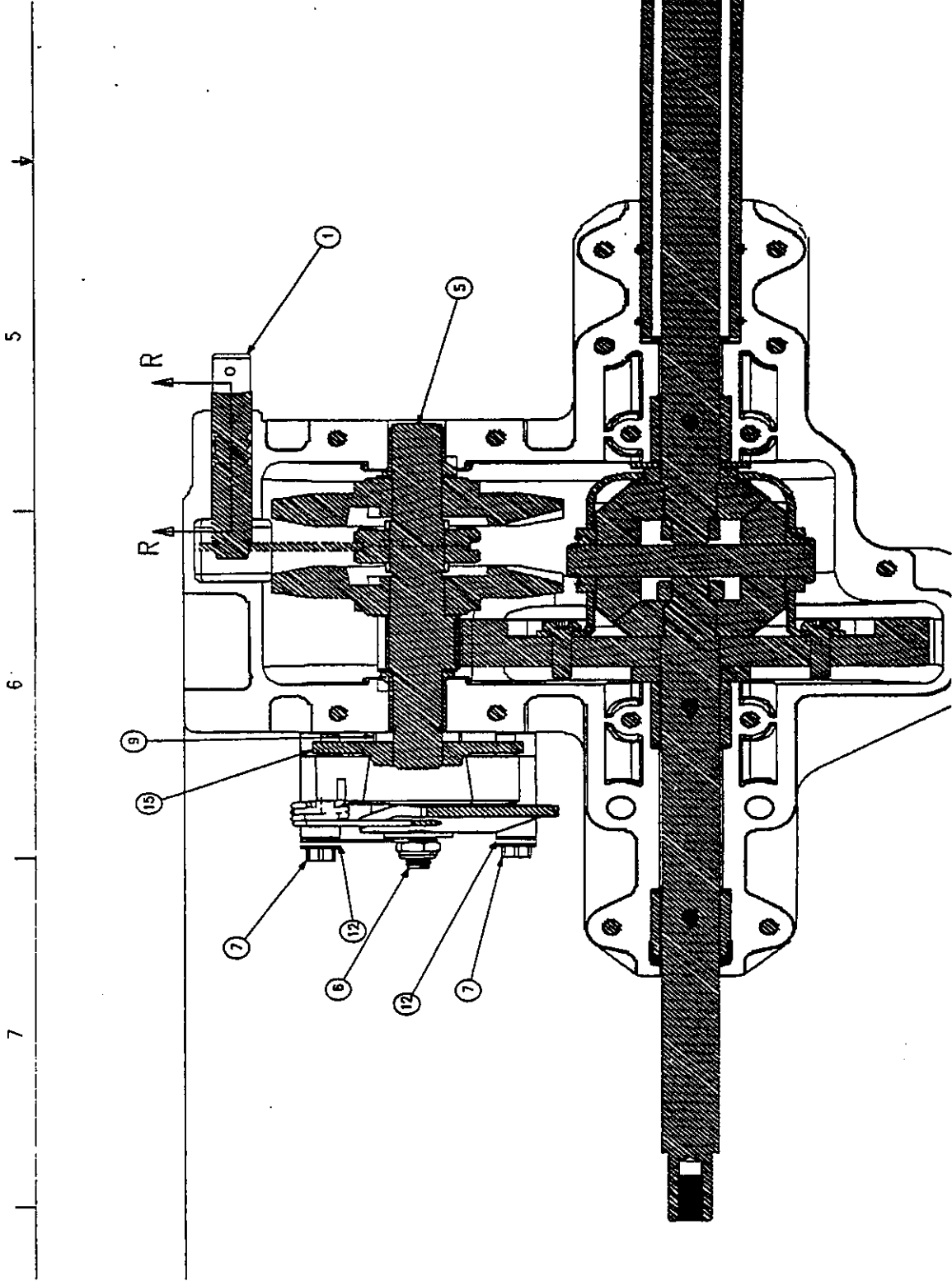

05/05/03

http://cpr-2.mtdproducts.com/pdis/eis/pol/cgm/618_0580.SH1.cgm

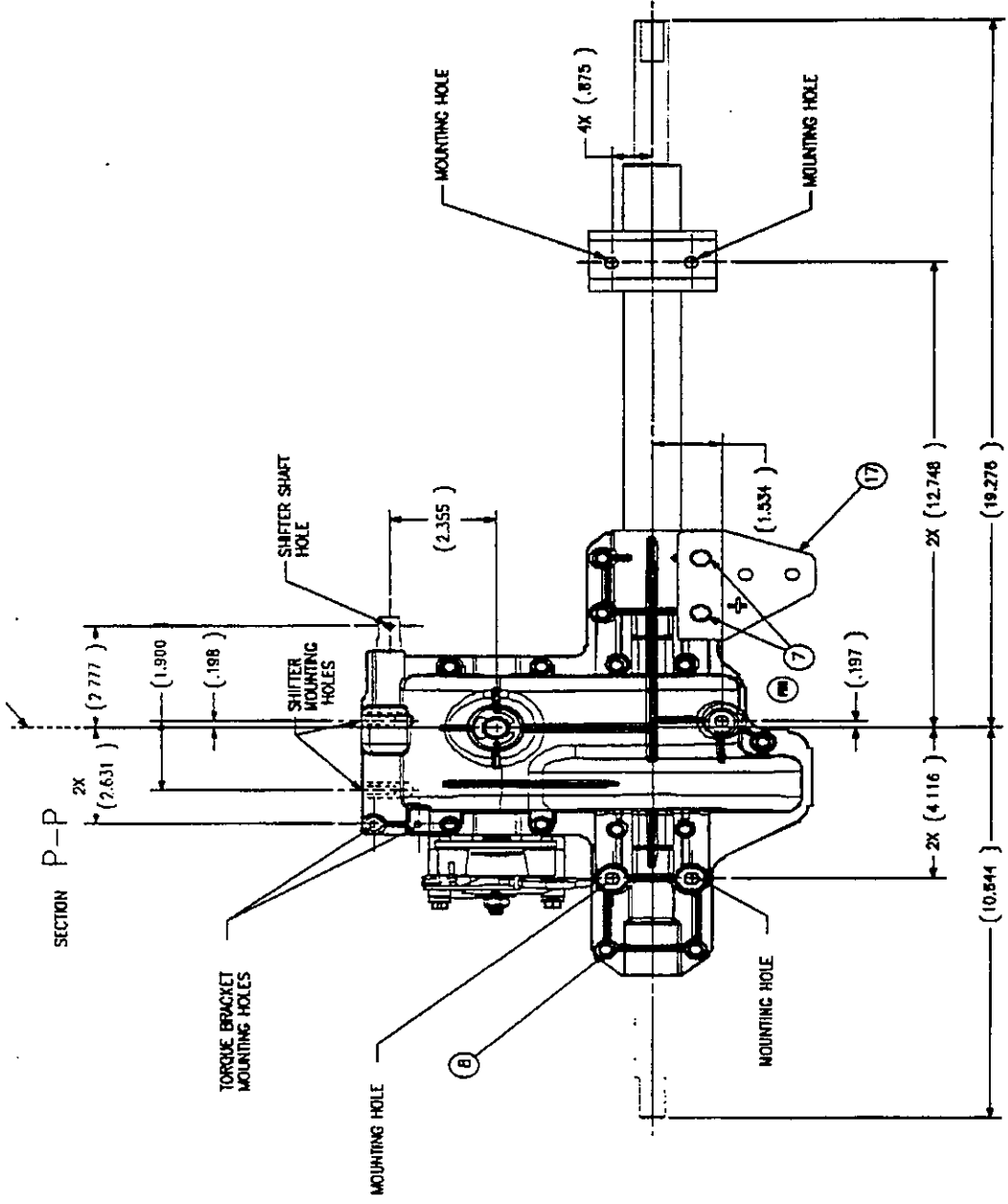

http://cpr-2.mtdproducts.com/pdis/eis/pol/cgm/618_0580.SH1.cgm

05/05/03

ITEM NO.	QTY	PART NO.	DESCRIPTION
1	1	611 0146	SHE ASM:DEFINT
2	1	618 0582	TUBE ASM:ORING & BRG
3	1	618 0583	DIF ASM:SNGL SPD
4	1	618 0584	HSG ASM:UPR
5	1	618 0585,POD 1	SHE ASM:DRIVE:UH BRAKE
6	1	661 0006	BRAKE ASM:YOKE:UH
7	4	710 1206	SCR:TI:1/4-20:2.375:HINDWSH
8	13	710 1325	SCR:TI:1/4-20:1.625:HINDWSH
9	1	717 0678	PAO:BRK
10	1	719 0573,POD 1	HSG:WR
11	1	732 1032	SPR:COMPRES:2569X,1549X,5480
12	1	736 0142,PO1 2	WASH:FLAT:281 X .50 X .063
13	1	737 0148	GRES:
14	1	741 1134	BAL:DEINT:7/32
15	1	761 0202	DISC:BRAKE
16	1	777X40217	LBL:ID:TRANS MODEL
17	1	783 1363	BRKT:MT:HITCH

(00)
 -NOT SHOWN-
 -NOT SHOWN-

PROJ. NO.	1708	DRAWN BY	LABUS	DATE	10/05/2000
DATE	05/08/2002	APPR. BY	MID APPROVED	DATE	05/08/2002
SCALE	1/1	FILE	ESM	REV	1

REV	PO0
ITEM NO.	618 0580
DESCRIPTION	TRANS ASM:SNGL SPD
DATE	05/08/2002
BY	MID APPROVED
DATE	05/08/2002

MPD
 MID PRODUCTS, INC.
 P.O. BOX 368022
 CLEVELAND, OH 44136-0015

500-Serie

Accessory Engine B&S INTEK -TWIN

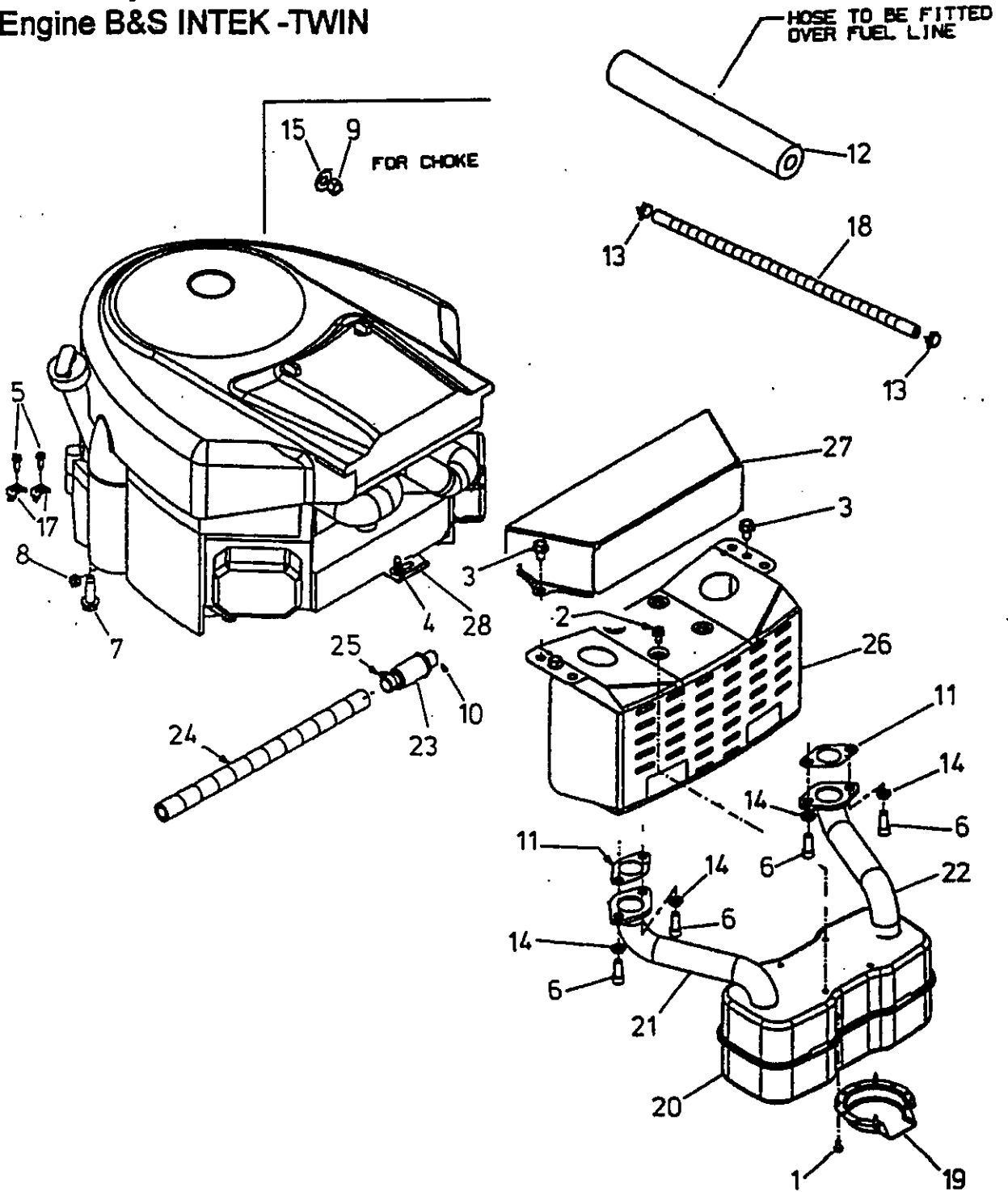

500er Serie

Accessory ,Engine INTEK TWIN

Ref	Order Nr	Description	Désignation	Bezeichnung	Standard	Qty
1	710-0227	Screw AB		6-Kant Schraube	8-18x0.500	4
2	710-0599	Screw TT		6-Kant Schraube	1/4-20x0.500	4
3	710-0604A	Screw TT		6-Kant Schraube	5/16-18x0.625	4
4	710-0726	Screw AB		6-Kant Schraube	5/16-15x0.750	1
5	710-1237	Screw		6-Kant Schraube	10-32x0.625	2
6	710-1314A	Hex Hd. Screw		6-Kant Schraube	5/16-18x.750	4
7	710-1315	Screw TT		Taptite Schraube	3/8-16x1.250	4
8	712-0271	Hex Nut		6-kt.Mutter	1/4-20	1
9	712-3017	Hex Nut		6-kt.Mutter	3/8-16	1
10	721-0331	Sealant Pipe Loctite		Rohrdichtmittel Loctite	.02	
11	721-0460	Gasket Exhaust Intek Twin		Auspuffdichtung Intek Twin		2
12	722-0263	Foam		Schutzschlauch-Schaumst.	.625x1.50x10.0	1
13	726-0205	Hose Clamp		Kabeldemme	.490 Dia	2
14	736-0119	L-Washer		Federring	5/16	4
15	736-0300	FI-Washer		Scheibe	.406x.675x.059	1
17	751B221535	Clamp Casing		Bowdenzugbefestigung		2
18	751-0535	Hose Fuel Line		Kraftstoffschlauch	14"	
19	751-0564	DFL Muffler		Auspuffdefektor		1
20	751-0616	Muffler Dual Inlet		Auspufftopf		1
21	751-0650	Pipe Exh. RH Intek Twin		Auspuffrohr re. Intek Twin		1
22	751-0651	Pipe Exh. LH Intek Twin		Auspuffrohr li. Intek Twin		1
23	751-3140	Oil Drain		Ölablaßstutzen		1
24	751-3141	Hose Extention Oil Drain		Ölablaßschlauch	12"	
25	751-3142	Cap Oil Drain		Verschlusskappe		1
26	783-0815B	Heatshield Muffler		Hitzeschild Auspuff		1
27	783-0625C	Heatshield Single		Hitzeschutzschild		1
28	783-0635	Bracket Limit. Throttle		Reglerhalter		1

500-Serie

Accessory Engine B&S INTEK Mod.21

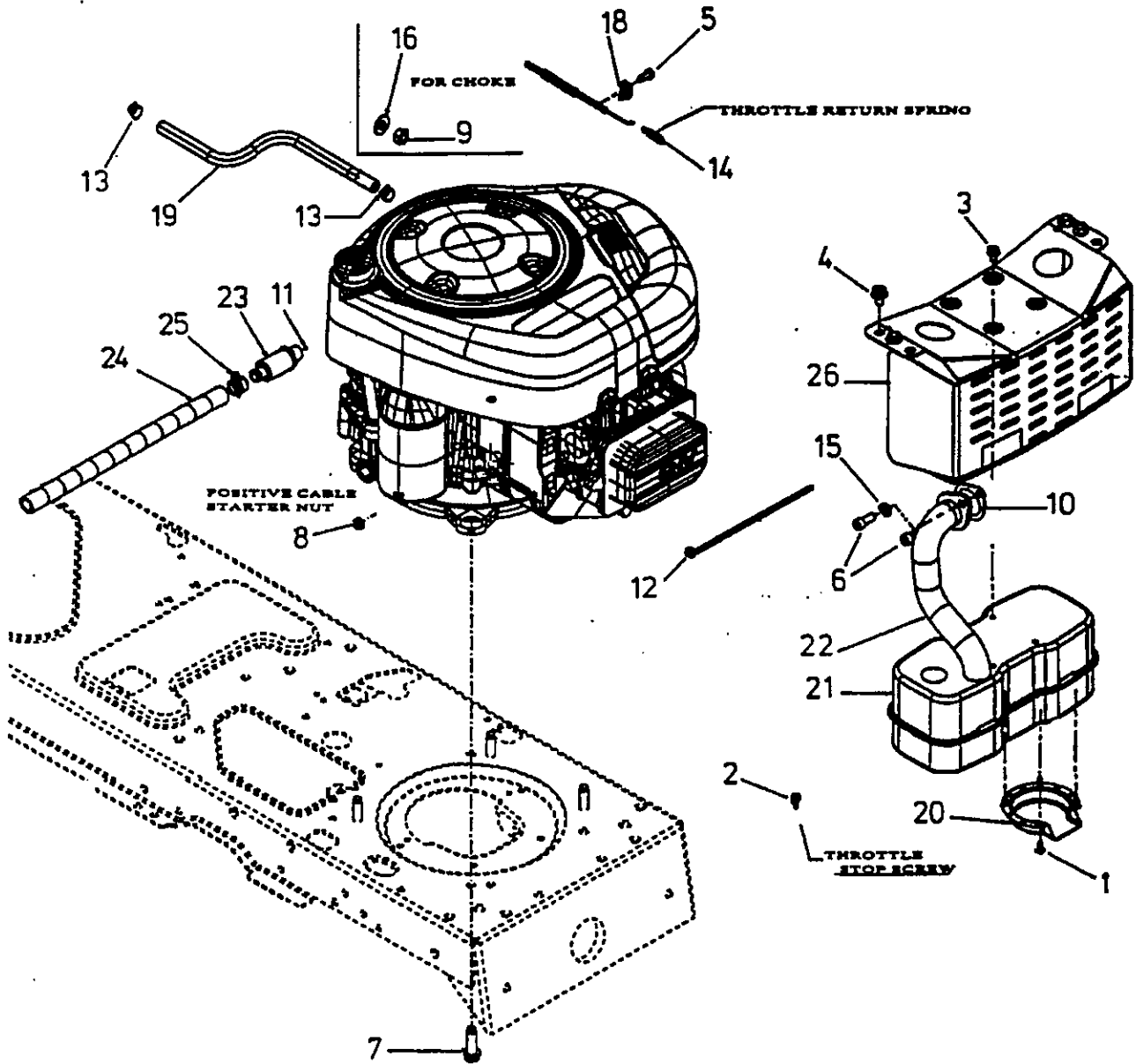

E3-01674A

500-er Serie

Accessory , Engine B&S INTEK Mod.21

Ref	Order Nr	Description	Désignation	Bezeichnung	Standard	Qty
1	710-0227	AB Screw Hbindwsh.		6-Kant Blechschraube	#8-16x0.500	4
2	710-0456	BSD Screw Hbindwsh.		6-Kant Schraube	#10-16x0.500	1
3	710-0599	TT Screw Hbindwsh.		6-Kant Schraube	1/4-20x0.500	4
4	710-0604A	TT Screw Hbindwsh.		6-Kant Schraube	5/16-18x0.625	4
5	710-1237	TT Screw Hbindwsh.		6-Kant Schraube	#10-32x0.625	1
6	710-1314A	Screw Soc. Hd.		6-Kant Schraube	5/16-18x.750	2
7	710-1315	Screw TT Hbindwsh.		Taptite Schraube	3/8-16x1.250	4
8	712-0271	Hex Sems Nut		6-Kant Mutter	1/4-20	1
9	712-3017	Hex Nut		6-Kant Mutter	3/8-16	1
10	721-0208	Exhaust Gasket		Dichtung (Auspuff)		1
11	721-0331	Sealent Pipe Pat. Loctite		Rohrdichtmittel Loctite	.02	
12	725-0157	Cabel Tie		Kabelbinder	3/16x.05x7.4	1
13	726-0205	Hose Clamp		Schlauchklemme	.490 Dia	2
14	732-0966	Extention Spring		Feder	.275Diax1.25Lg	1
15	736-0119	Lock Washer		Federring	5/16	2
16	736-0300	Flat Washer		Scheibe	.406x.875x.059	1
18	751B213148	Clamp Casing B&S Throttle		Kabelbefestigung		1
19	751-0535	Hose Fuel Line		Kraftstoffschlauch		15
20	751-0564	Muffler Deflector		Auspuff Abdeckung		1
21	751-0617	Muffler Single Inlet		Auspuff		1
22	751-0816A	Pipe Exhaust Single OHV		Auspuffrohr OHV B&S		1
23	751-3140	Oil Drain		Ölablaßstutzen		1
24	751-3141	Hose Exten. Oil Drain		Ölablaßschlauch		12
25	751-3142	Cap Drain Oil		Verschlusskappe		1
26	783-0615B	Shld. Heat Muffler		Hitzeschutz f. Auspuff		1

500-Serie

Accessory
Engine B&S OHV

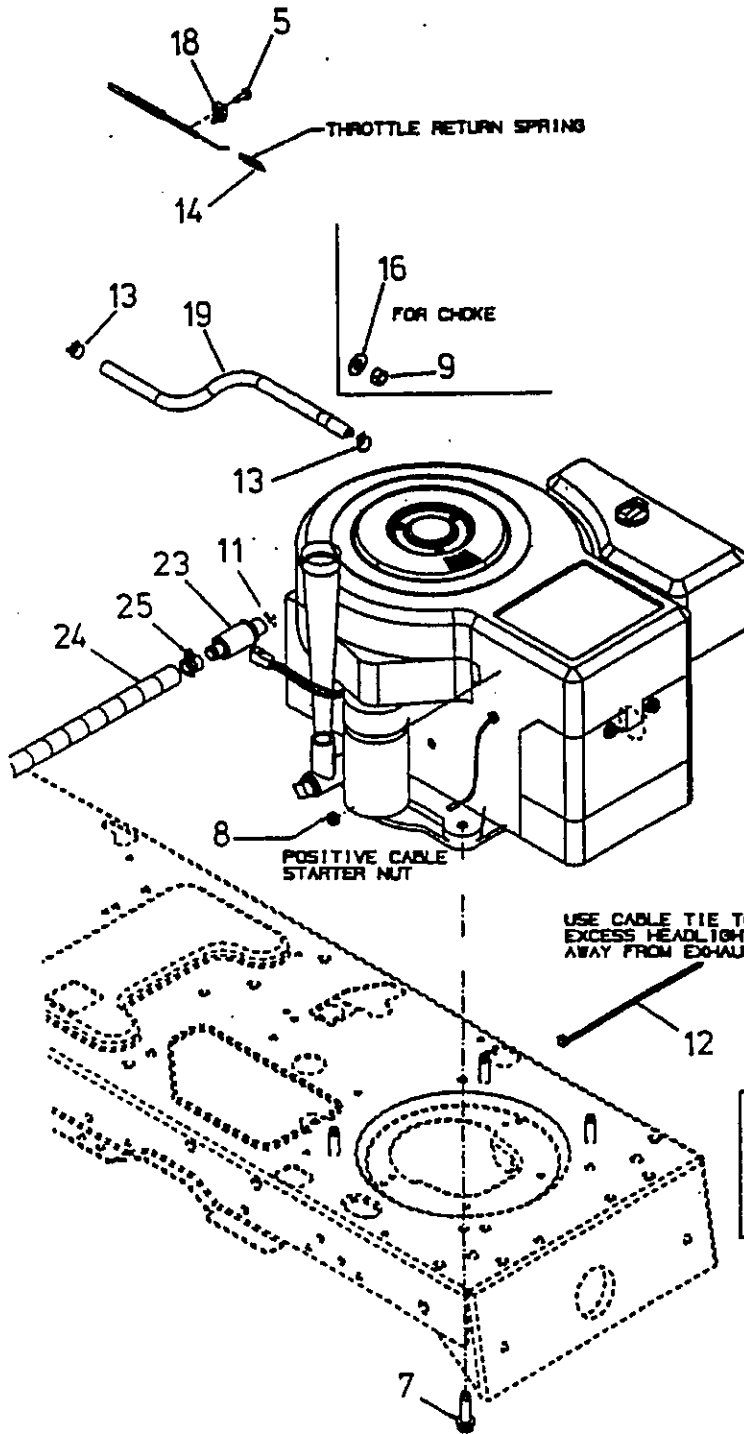

Accessory
Engine B&S Single

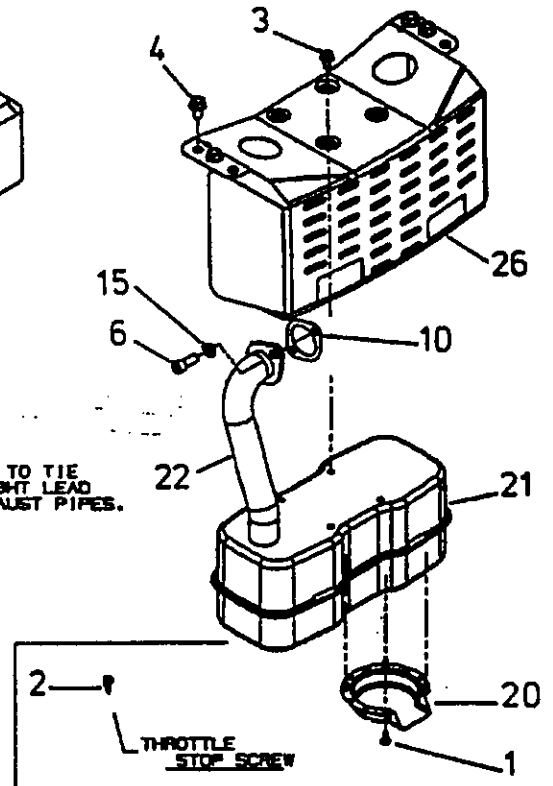
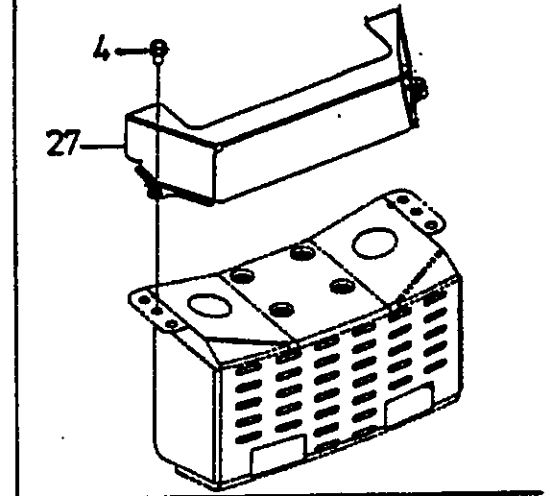

500er Serie

Accessory ,Engine B&S OHV Accessory ,Engine B&S Single

Ref	Order Nr	Description	Désignation	Bezeichnung	Standard	Qty
1	710-0227	Screw AB		6-Kant Schraube	8-18x0.500	4
2	710-0456	Hex Cap Screw		6-Kant Schraube	10-16x0.500	1
3	710-0599	Screw TT		6-Kant Schraube	1/4-20x0.500	4
4	710-0604A	Screw TT		6-Kant Schraube	5/18-18x0.625	4
5	710-1237	Screw TT		6-Kant Schraube	10-32x0.625	1
6	710-1314A	Screw SOC		6-Kant Schraube	5/16-18x.750	2
7	710-1315	Screw TT		6-Kant Schraube	3/8-16x1.250	4
8	712-0271	Hex Nut		6-kt.Mutter	14-20	1
9	712-3017	Hex Nut		6-kt.Mutter	3/8-16	1
10	721-0208	Gasket Exhaust		Dichtung (Auspuff)		1
11	721-0331	Sealant Pipe Loctite		Rohrdrichtmittel Loctite 562	.02	
12	725-0157	Cabel Tie		Kabelbinder		1
13	726-0205	Hose Clamp		Schlauchdemme	.490 Dia	2
14	732-0966	Spring Extension		Feder		1
15	736-0119	Lock Washer		Federring	5/18	2
16	736-0300	Fl. Washer		Scheibe	.406x.875x.059	1
18	751B213146	Clamp Casing Throttle		Kabelbefestigung		1
19	751-0535	Hose Fuel Line		Kraftstoffschlauch	15"	
20	751-0564	Deflector Muffler		Auspuff Deflektor		1
21	751-0617	Muffler Single Inlet		Auspuff		1
22	751-0619	Pipe Exhaust Single		Auspuffrohr		1
23	751-3140	Oil Drain		Ölablaßstutzen		1
24	751-3141	Hose Extn. Oil Drain		Ölablaßschlauch	12"	
25	751-3142	Cap Oil Drain		Verschlußkappe		1
26	783-0615B	Heatshield Muffler		Auspuff-Hitzeschutz		1
27	783-1354A	Heat Shield ,B&S-Single		Hitzeschutzschild für Motor B&S -Single		1

500-Serie Transmatic , Hydro

Man.PTO -Engine Pulley ,GT BRC

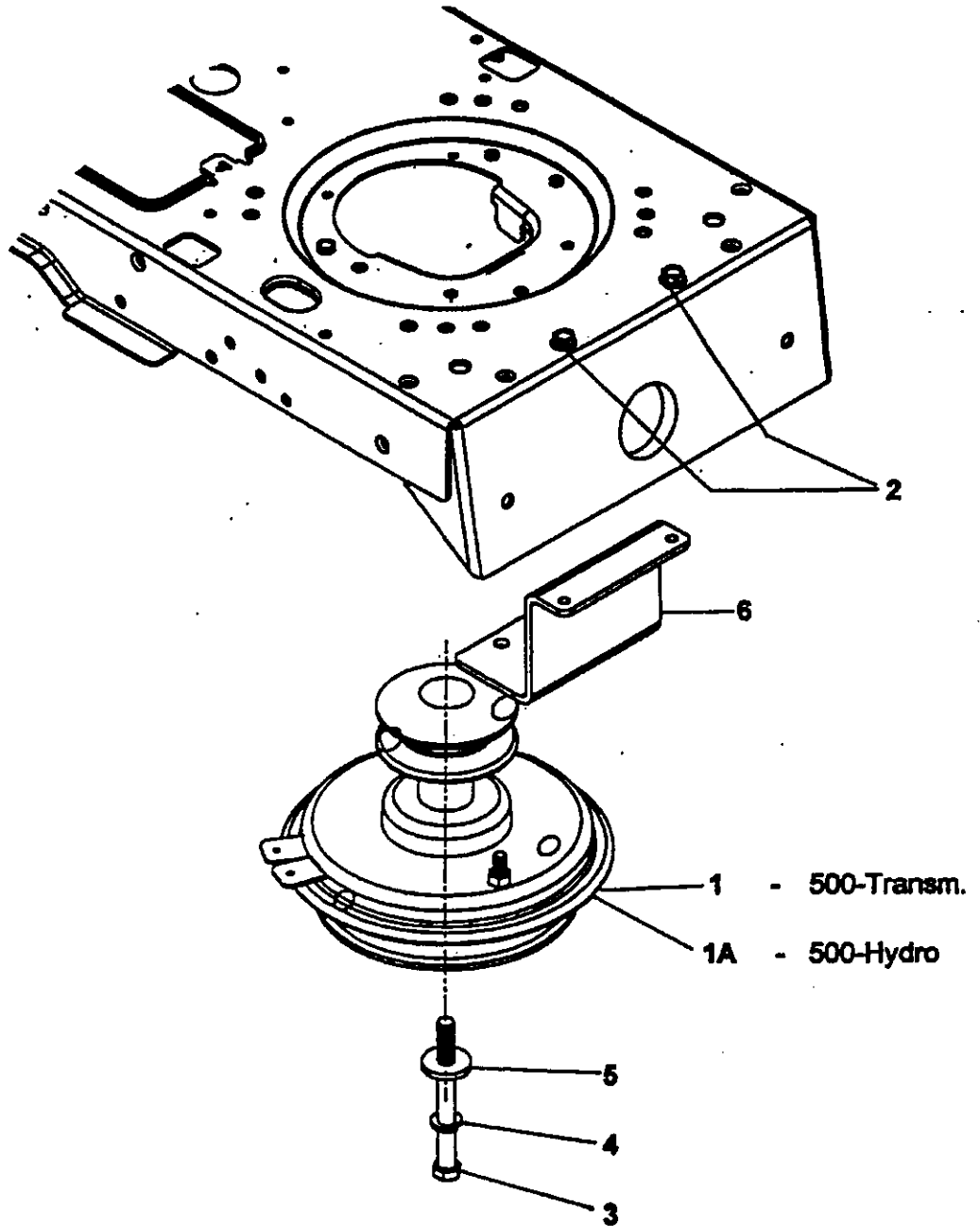

500er Serie , Transmatic / Hydro

Man.PTO -Engine Pulley , GT BRC

Ref	Order Nr	Description	Désignation	Bezeichnung	Standard	Qty
1	717-1787	Clutch Assy 500-Transmatic		Kupplung vollst. 500-Transmatic		1
1A	717-1788	Clutch Assy 500-Hydro		Kupplung vollst. 500-Hydro		1
2	710-1280A	Screw TT		6-Kant Schraube	5/16-18 x 0.75	2
3	710-04002	Screw TT		6-Kant Schraube	7/16-20x4.50	1
4	736-0171	L-Washer		Federring	7/16	1
5	736-0322	Fl.Washer		Scheibe	.450x1.250x.164	1
6	783-04000	Brkt. Stop		Halter-Stop-Man.PTO		1

500er Serie

PTO Manual - Engine

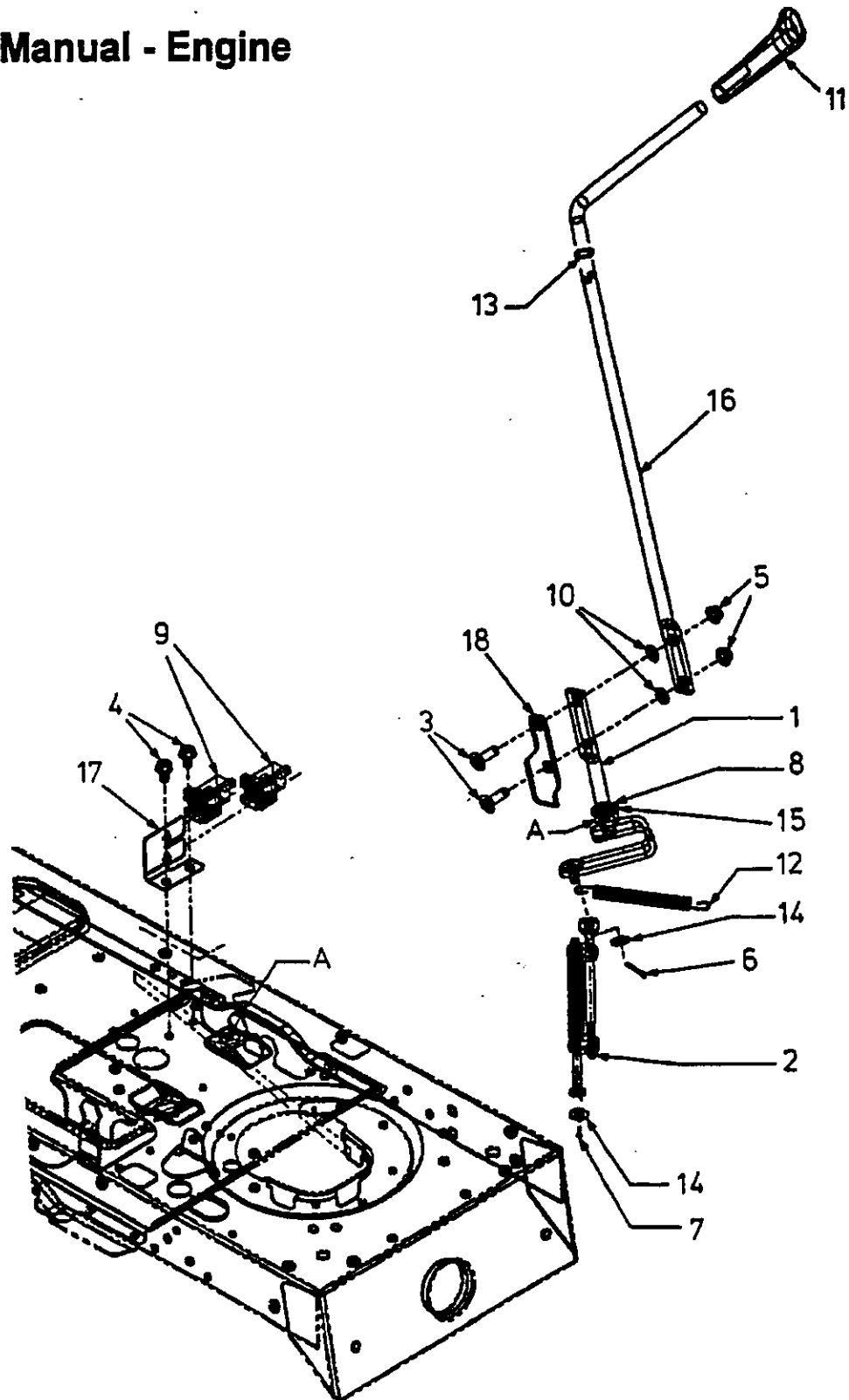

500er Serie

PTO Manual - Engine

Ref	Order Nr	Description	Désignation	Bezeichnung	Standard	Qty
1	647-0066	Lever Assy Engage		Einschaltkonsole		1
2	647-0067	Rod Assy		Kupplungsstange vollst.		1
3	710-0276	Carriage Screw		Fl. Rundschraube	5/16-18x1.0	2
4	710-0604A	Screw TT		6-Kant Schraube	5/16-18x0.625	2
5	712-3004A	Flange L-Nut		6-kt. Mutter	5/16-18	2
6	714-0470	Cotter Pin		Splint	1/8x1.25	1
7	714-0507	Cotter Pin		Splint	3/32x.750	1
8	716-0104	E-Ring		Sicherungsring		1
9	725-1657A	Switch Intlk. PTO		Schalter ,PTO		2
10	726-0201	Speed Nut		Nutmutter	.3125Dia	2
11	731-2111A	Knob PTO		Handgriff PTO		1
12	732-1165	Extention Spring		Feder	.50Diax5.0Lg	1
13	736-0108	Fl. Washer		Scheibe	.510x.750x.033	1
14	736-0275	Fl. Washer		Scheibe	.344x.688x.065	2
15	741-0708	Bearing Flange Hex Split		Flanschlager		1
16	747-1112D	Handle Deck Engage		Einschalthebel Deck		1
17	783-1438	Brkt. Sw. PTO		Halter Schalter PTO		1
18	783-1497	Brkt. Engage Stop		Verbindungsflasche		1

500er Série

Steering , Adjustable

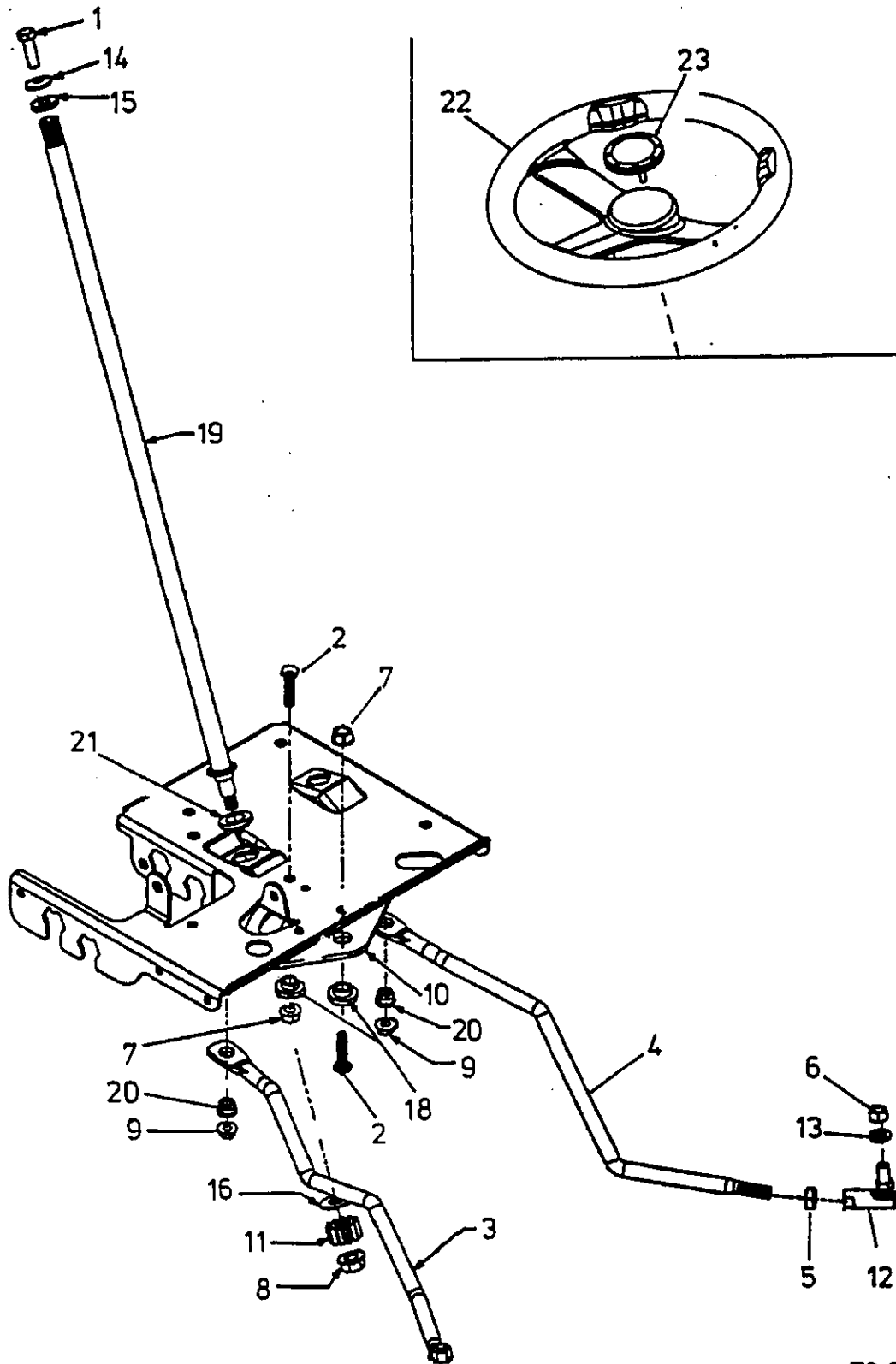

500er Serie

Steering , Adjustable

Ref	Order Nr	Description	Désignation	Bezeichnung	Standard	Qty
1	710-0543	Hex Hd. Screw		6-Kant Schraube	5/16-18x1.00	1
2	710-0723	Hex Hd. Screw		6-Kant Schraube	3/8-16x1.25	2
3	711-1408	Link Drag RH		Verbindungsstange re.		1
4	711-1655	Link Drag LH		Verbindungsstange li.		1
5	712-0240	Jam Nut		6-Kant Mutter	7/16-20	2
6	712-0241	Hex Nut		6-Kant Mutter	3/8-24	2
7	712-0431	Flange L-Nut		Sicherungsmutter	3/8-16	2
8	712-0459	Flange L-Nut		Sicherungsmutter	7/16-20	1
9	712-3004A	Flange L-Nut		Sicherungsmutter	5/16-18	2
10	717-1550D	Gear Strg. Ratio		Lenksegment		1
11	717-1554	Gear Pinion Strg.		Ritzel-Lenkung		1
12	723-0448A	B/Jnt		Kugelgelenk	7/16-20	2
13	736-0169	Lock Washer		Federring	3/8	2
14	736-0242	Bell Washer		Tellerfeder	.340x.672x.060	1
15	736-3004	Fl. Washer		Scheibe	.406x.675x.105	1
16	736-3084	Fl. Washer		Scheibe	.510x1.120x.060	1
18	738-0372B	Shoulder Spacer		Distanzstück	1.00x.38x.38	2
19	738-1001A	Shaft Steering		Lenkwelle	.625ODx24.25Lg	1
20	741-0475	Plastic Bushing		Buchse	.380ID	2
21	741-0656	Flange Bearing		Lagerbuchse mit 6-Kant	5/8	1
22	731-2624	Steering Wheel , Soft Grip		Lenkrad		1
23	731-2625	Steering Wheel Cap		Lenkradkappe		1

500er Serie

Rear Wheels

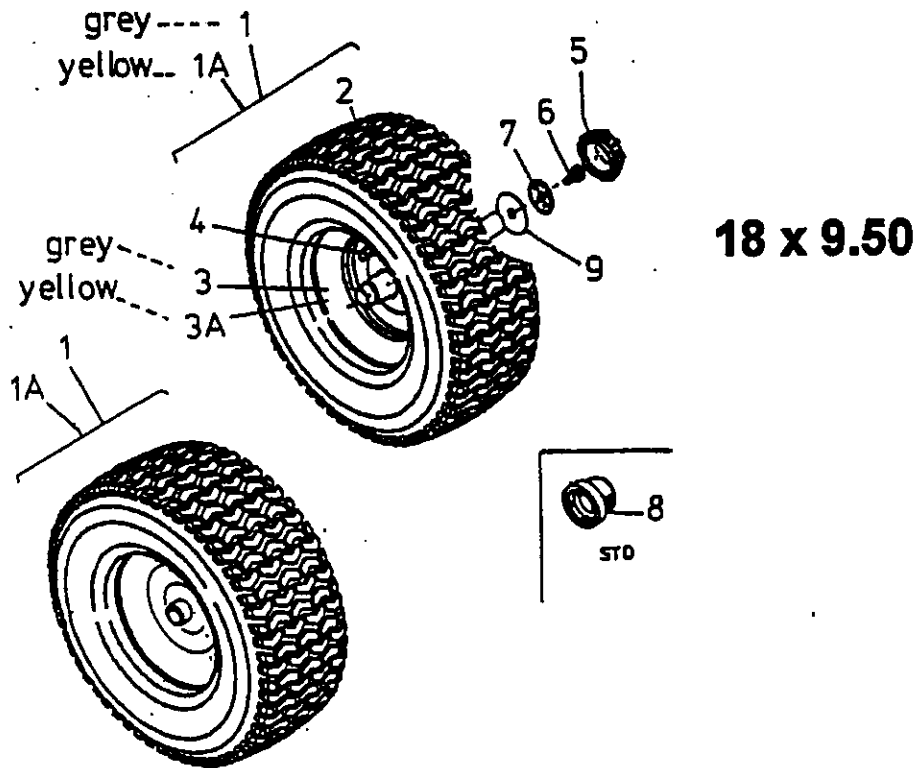

18 x 6.50

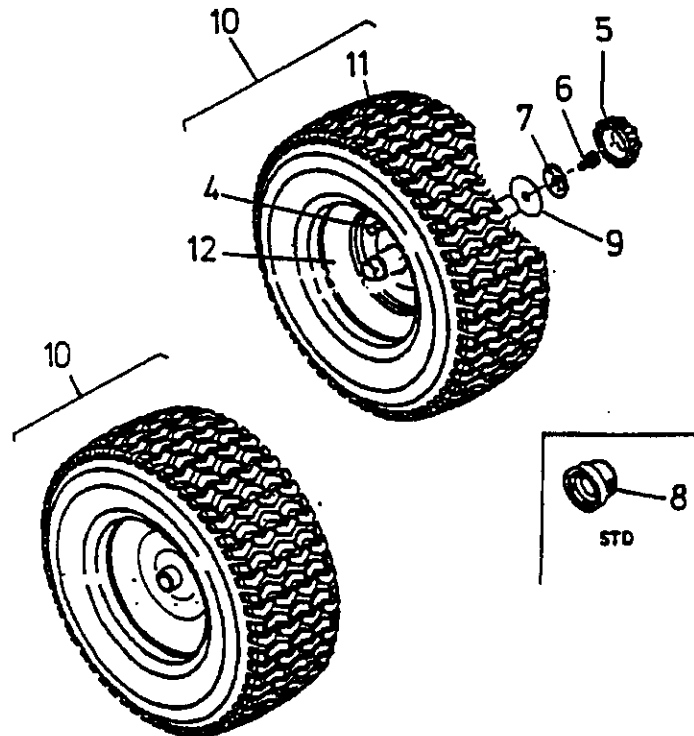

E3-01663A

Rear Wheels

Ref	Order Nr	Description	Désignation	Bezeichnung	Standard	Qty
18 x 9.5						
1	734-0817662	Wheel Cpl. 18x9.5 Grey, incl.2 - 4	Roue cpl.18x9.5 Gris, incl.2 - 4	Rad Kpl. , Grau incl.2 - 4	18 x 9.50	2
1A	734-0817674	Wheel Cpl. 18x9.5 Yellow, incl.2 - 4	Roue cpl.18x9.5 Jaune, incl.2 - 4	Rad Kpl. , Gelb incl.2 - 4	18 x 9.50	2
2	734-0448	Tire 18 x 9.5	Bandage	Reifen	18 x 9.5	2
3	634-0070662	Rim , Grey	Jante , Gris	Felge , Grau	8 x 7 x .750 ID.	2
3A	634-0070674	Rim , Yellow	Jante , Jaune	Felge , Gelb	8 x 7 x .750 ID.	2
4	734-0255	Valve	Soupape	Luftventil	TR 412-P	2
5	731-2280A	Hub Cap	Cap.de roue	Radkappe		2
6	710-0627	Hex.Bolt ,Lock	Vis	6-kt.Schraube	5/16-24 x .750	2
7	736-0242	Belleville Washer	Rond.Belleville	Teilerfeder	.340 IDx.872 OD	2
8	731-0484A	Hub Cap , STD	Cap.de roue , STD.	Radkappe , STD.	1.56"/1.64" ID	2
9	736-0430	Fl.Washer	Rondelle	Scheibe	.350x1.59 x .062	2
18 x 6.5						
10	734-0592662	Wheel Cpl. 18x6.5 Grey, incl.2 - 4	Roue cpl.18x6.5 Gris, incl.2 - 4	Rad Kpl. 18x6.5 Grau, incl.2 - 4	18 x 6.50	2
11	734-0294	Tire 18x6.50	Bandage 18x6.50	Reifen 18x6.50	18 x 6.50-8	2
12	634-0069662	Rim , Grey	Jante , Gris	Felge , Grau	8x5.38x .750 ID.	2

500er Serie

Front Wheels 15 x 6

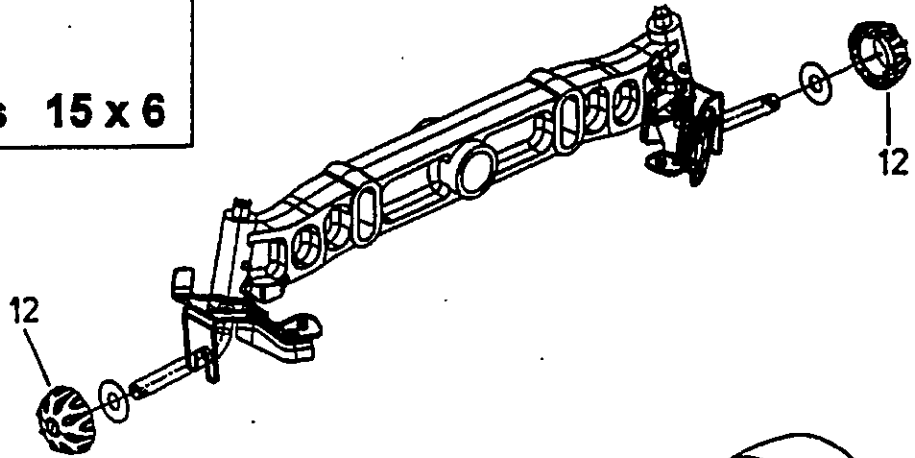

15 x 6 , Plast.Bearing

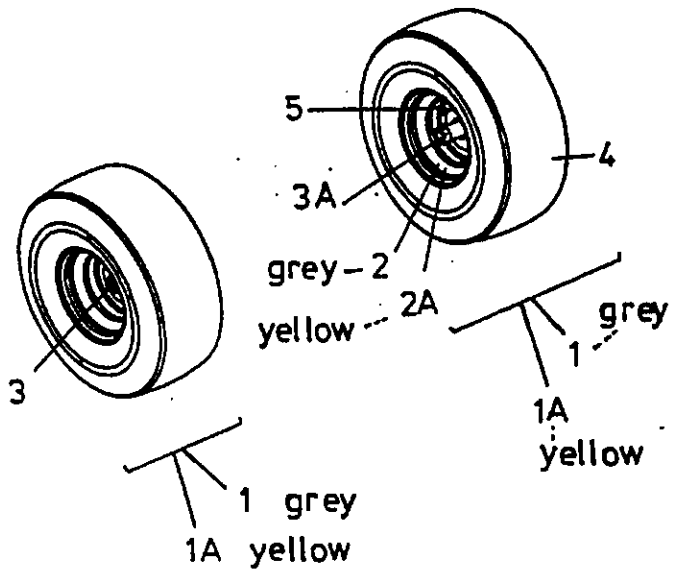

Wheels 15" x 6 (Ball Bearing / Roulá Billes / Kugellager

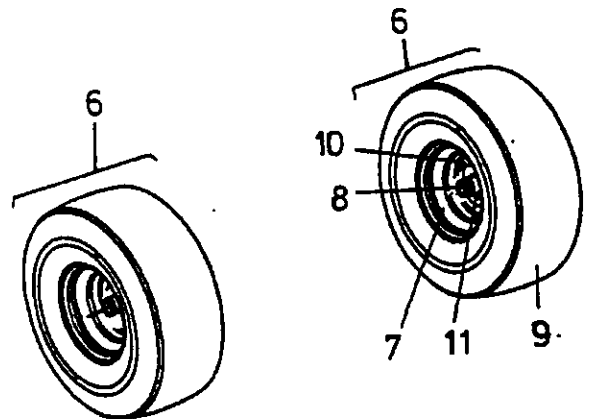

500er Serie

Front Wheels 15 x 6

Ref	Order Nr	Description	Désignation	Bezeichnung	Standard	Qty
Wheel 15 x 6 , Plast.Bearing						
1	634-0105A662	Wheel Cpl. ,Grey (Plast.) incl.2 - 5	Roue cpl. Gris incl.2 - 5	Rad Kpl. Grau (Kunstst.) incl.2 - 5	15x6.0-6	2
1A	634-0105A674	Wheel Cpl. ,Yellow (Plast.) incl.2 - 5	Roue cpl. Jaune incl.2 - 5	Rad Kpl. Gelb (Kunstst.) incl.2 - 5	15x6.0-6	2
2	634-0172662	Rim compl. , Grey	Jante , Gris	Felge vorn , Grau	6.0x4.5	2
2A	634-0172674	Rim compl. , Yellow	Jante , Jaune	Felge vorn , Gelb	6.0x4.5	2
3	741-0487A	Flange Bearing ,Plast.	Palier	Flanschlagerbuchse	.632" ID.	2
3A	741-0706	Flange Bearing ,Plast. incl.Grease Nipple	Palier avec Graisseur	Flanschlagerbuchse mit Schmiernippel	.635 ID.x.817 OD	2
4	734-1731	Tire	Bandage	Reifen	15x600-6	2
5	734-0255	Valve	Soupape	Luftventil	TR 412-P	2
Wheels 15" x 6 (Ball Bearing / Roul.á Billes / Kugellager						
6	634-0115A662	Wheel Cpl. ,Grey (Ball B.) incl.2 - 6	Roue cpl. , Gris incl.2 - 6	Rad kpl.Grau (Kugellager) incl.2 - 6	15x6x6 ,SQ	2
7	634-0051662	Rim compl. , Grey	Jante , Gris	Felge vorn , Grau	6.0x4.5 , BB	2
8	741-0569	Ball Bearing	Roulem. á bille	Kugellager		4
9	734-1731	Tire	Bandage	Reifen	15x600-6	2
10	734-0255	Valve	Soupape	Luftventil	TR 412-P	2
11	737-0280	Grease Nipple	Graisseur	Schmiernippel		2
12	731-2290A	Cap Hub		Radkappe klein		2

500er Serie

813-50031

Seat ,Adjust.

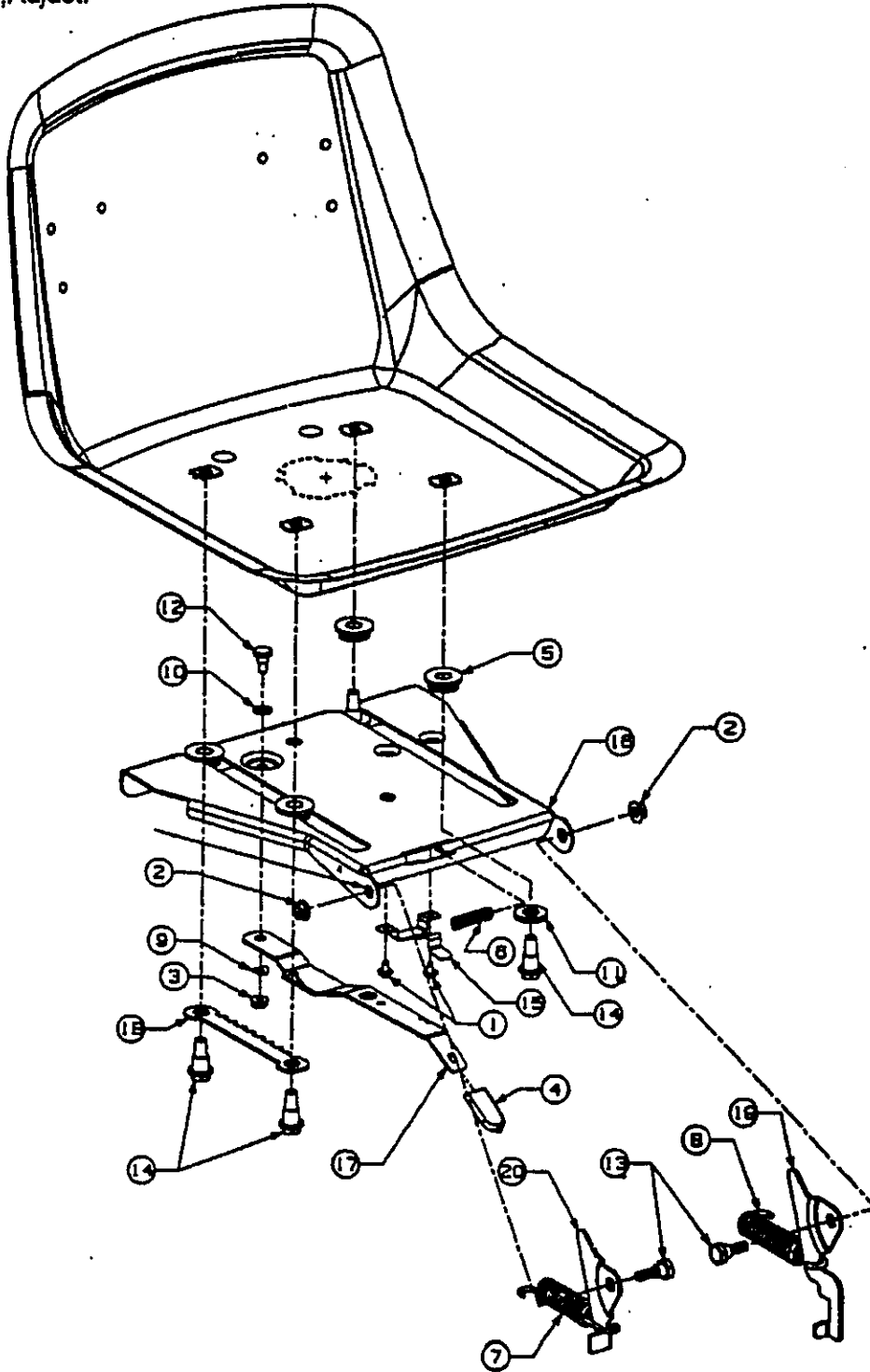

E3-01609A

62

500er Serie

Seat ,Adj.

Ref	Order Nr	Description	Désignation	Bezeichnung	Standard	Qty
1	710-1268	Screw		6-Kant Schraube	10-18x0.375	2
2	712-3004A	Flange L-Nut		6-kt.S.Mutter	5/16-18	2
3	712-3027	Nut		6-kt.S.Mutter	1/4-20	1
4	720-0309A	Grip Seat Adj.		Gummigriff-Sitz		1
5	731-1989	Spacer Seat Adj.		Distanzstück Sitzeinstellung		4
6	732-0499	Compression Spring		Druckfeder	.41x1.50	1
7	732-1027	Extention Spring		Feder	.800x4.2	1
8	732-1175	Extention Spring		Feder	.815x4.4	1
9	736-0175	Spring Washer		Federscheibe	.285x.562x.025	1
10	736-0204	Fl. Washer		Scheibe	.344x.62	1
11	736-3019	Fl. Washer		Scheibe	.531x1.062x.134	2
12	738-0137A	Shoulder Screw		Schultererschraube	.340x.285x1/4-20	1
13	738-0296	Shoulder Screw		Schultererschraube	.437x.286	2
14	738-1007	Shoulder Screw		Schultererschraube	.50x.50x38-16	4
15	783-0611	Stop Seat Adj.		Sitzanschlag		1
16	783-0736	Brkt. Pivot Seat		Sitzträger		1
17	783-0739	Lever Seat Adj.		Sitzverstellhebel		1
18	783-0753	Seat Adjustment Selector		Verstellraste f. Sitzversti.		1
19	783-1366	Brkt Seat Lift		Kontaktplatte-Sitzschalter		1
20	783-1430	Brkt. Lift Seat		Kontaktplatte-Sitzschalter		1

500er Serie

813-50082

Seat, Standard

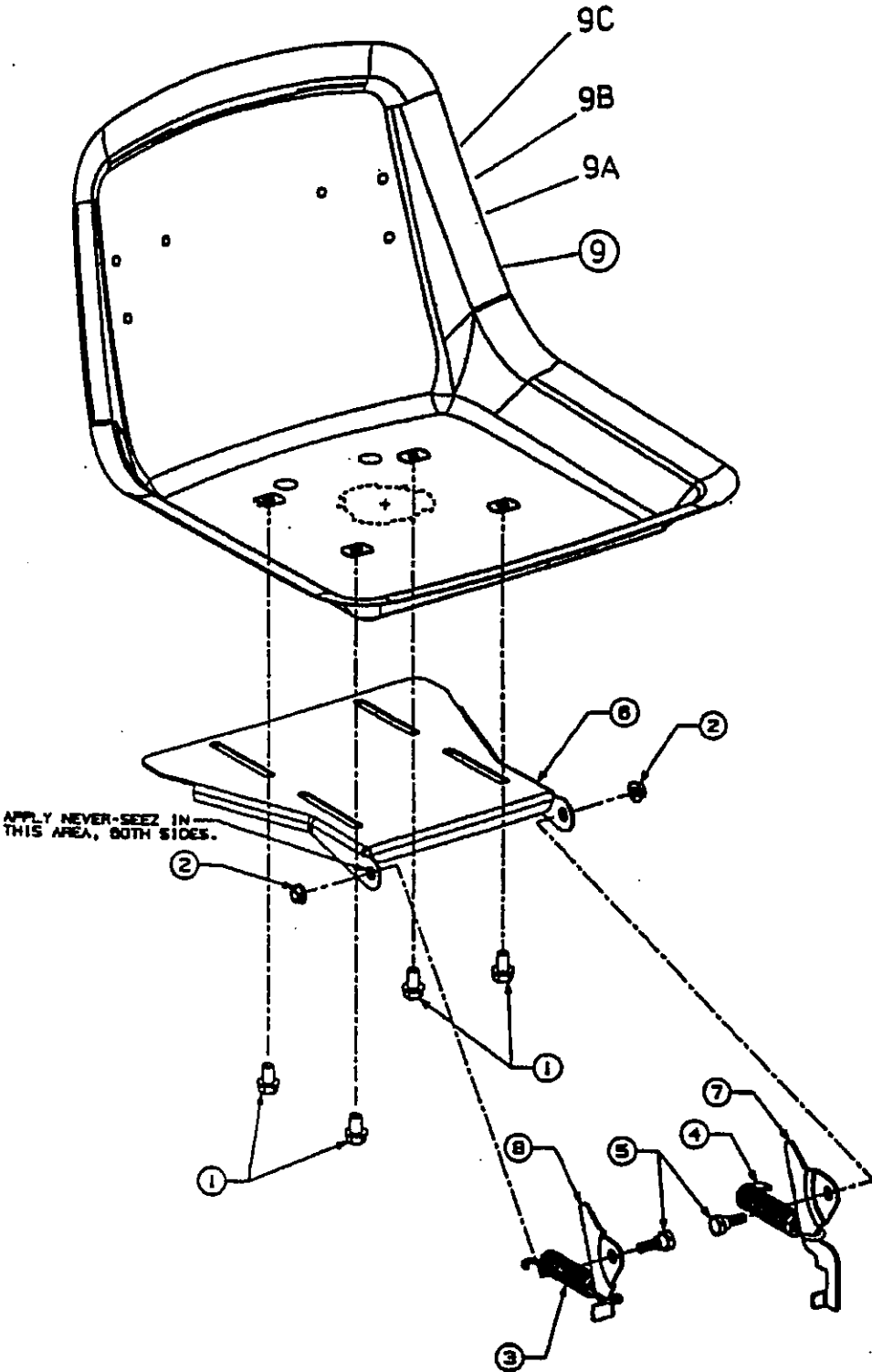

E3-01608A

500er Serie

Seat ,Standard

Ref	Order Nr	Description	Désignation	Bezeichnung	Standard	Qty
1	710-0870	Hex Washer		6-kt.Schraube	3/8-16x.625	4
2	712-3004A	Flange L-Nut		6-kt.-S.Mutter	5/16-18	2
3	732-1027	Extention Spring		Zugfeder	.800ODx4.20LG	1
4	732-1175	Extention Spring		Zugfeder	.815ODx4.4LG	1
5	738-0296	Shoulder Screw		Schulter Schraube	.437x.266LG	2
6	783-0740	Brkt. Pivot Seat Man Adj.		Halteplatte Sitz		1
7	783-1366	Brkt. Seat Lift		Kontaktplatte-Sitzschalter		1
8	783-1430	Brkt. Lift Seat		Kontaktplatte-Sitzschalter		1
9	757-0360A	Seat black ,Medium Back		Sitz schwarz , Medium	V-380	1
9A	757-0365A	Seat yellow,Medium Back		Sitz gelb , Medium		1
9B	757-0372	Seat yellow, High Back		Sitz gelb , High Back		1
9C	757-0350	Seat black , High Back		Sitz schwarz, High Back	14-1	1

500er Serie Frame , Hydro

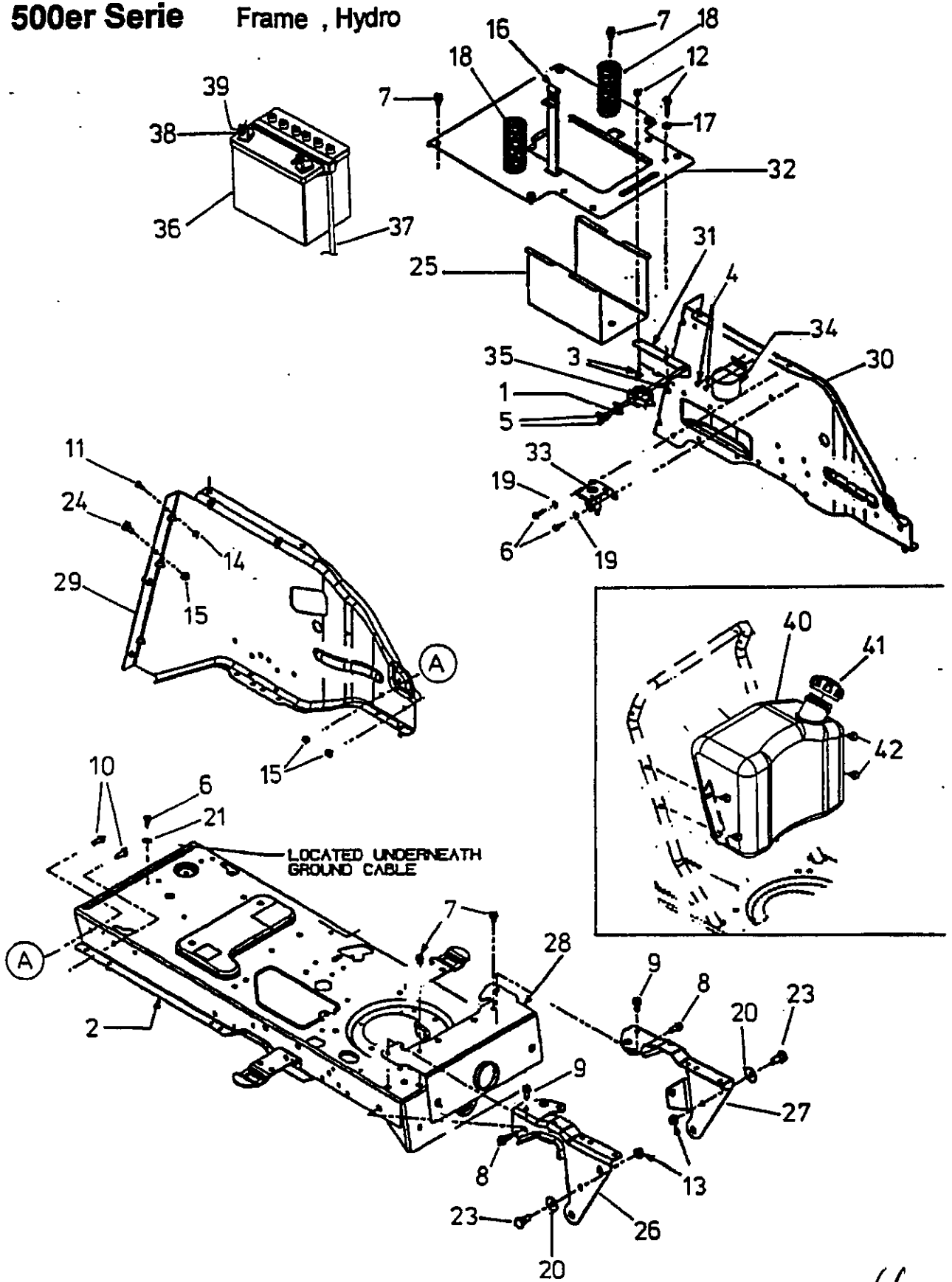

500er Serie

Frame , Hydro

Ref	Order Nr	Description	Désignation	Bezeichnung	Standard	Qty
1	17962	Switch Plate		Stützplatte für Schalter		1
2	683-0586	Frame Assy		Rahmen vollst.		1
3	710-0134	Carriage Screw		Fl. Rundschraube		2
4	710-0148	Screw		6-Kant Schraube	8-32x0.375	2
5	710-0224	Screw AB		6-Kant Schraube	10-16x0.500	2
6	710-0599	Screw TT		6-Kant Schraube	1/4-20x0.500	3
7	710-0604A	Screw TT		6-Kant Schraube	5/16-18x0.625	8
8	710-1238	Hex Cap Screw		6-Kant Schraube	5/16-18x.675	2
9	710-1260A	Screw LD		6-Kant Schraube	5/16-18x0.750	2
10	710-1681	Hex Cap Screw		6-Kant Schraube	M8	6
11	710-1691	Screw		6-Kant Schraube	M6	3
12	712-0291	Hex Lock Nut		Stopmutter	1/4-20	2
13	712-0431	Flange L-Nut		Sicherungsmutter m.Flansch	3/8-16	2
14	712-0691	Hex Lock Nut		Sicherungsmutter	M6 DIN 985	3
15	712-0692	Hex Lock Nut		Sicherungsmutter	M8 DIN 985	10
16	723-0444	Battery Strap		Batteriegurt		1
17	726-0353	Ret. Bolt Push On		Achsen-Klemmring		2
18	732-1034	Compression Spring		Druckfeder		2
19	736-0222	Lock Washer		Zahnscheibe	1/4"	2
20	736-0331	Bell Washer		Teilerfeder	.390x1.13x.062	2
21	736-0498	Lock Washer		Federring	1/4"	1
23	738-0143	Shoulder Screw		Schulter-Schraube	3/8-16	2
24	738-0140	Shoulder Screw		Schulter-Schraube		4
25	783-0349	Battery Tray		Batteriekasten		1
26	783-0726B	Brkt. Pivot Support RH		Vorderachshalter rechts		1
27	783-0727A	Brkt. Pivot Support LH		Vorderachshalter links		1
28	783-0728	Brkt. Pivot Bar		Vorderachsträger		1
29	783-1318	Frame Rear right		Rahmen Hinten Rechts		1
30	783-1370	Frame Rear left		Rahmen Hinten Links		1
31	783-1387	Brkt Rod Shift		Halter Aushebestange		1
32	783-1410	Plate Top		Abdeckplatte hinten		1
33	725-1426	Solenoid		Magnetschalter	12V , 100A	1
34	725-1802	Signal Dvice		Signalgeber		1
35	725-2013	Switch ,interlock		Schalter		1
36	725-2057	Battery , Dry		Batterie	U1 ,245 CCA	1
37	750-04016	Drain Hose		Schlauch ,Drain.		1
38	710-3015	Screw		Schraube	1/4-20 x .75 lg.	2
39	712-0271	Hex.Nut		6-kt.Mutter	1/4-20	2
40	751-0818	Fuel Tank , 2 Gal	Reservoir	Tank , 2.0 Gallone		1
41	751-0603	Fuel Cap	Capuchon	Tankdeckel		1
42	710-0604A	Screw TT	Vis	6-Kant Schraube	5/16-18x0.625	4

500er Serie

813-50000

Frame, Transmatic

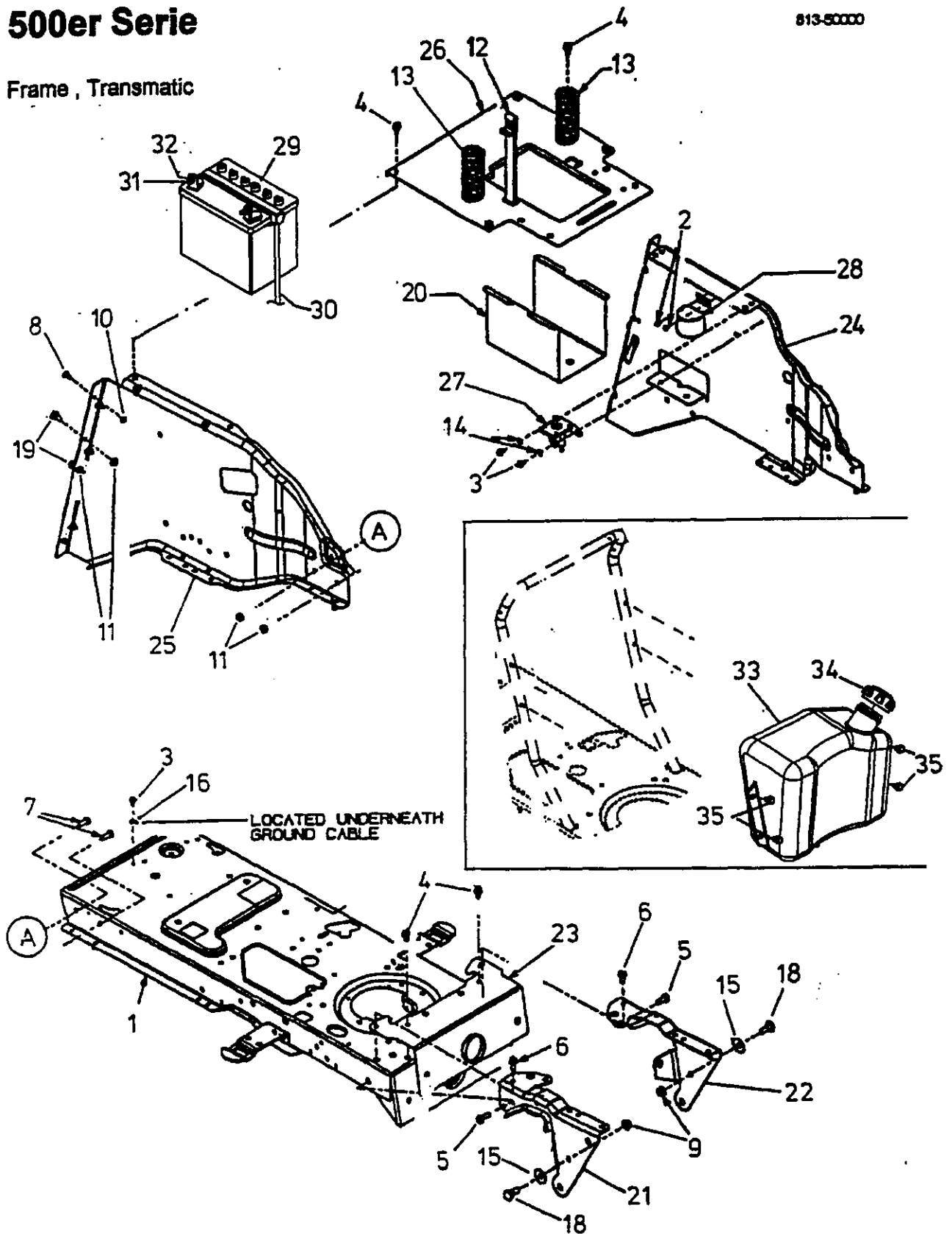

E3-01606A

68

500er Serie

Frame , Transmatic

Ref	Order Nr	Description	Désignation	Bezeichnung	Standard	Qty
1	683-0586	Frame Assy Lower		Rahmen vollst. unten		1
2	710-0148	Screw		6-Kant Schraube	8-32x0.375	2
3	710-0599	Screw TT		6-Kant Schraube	1/4-20x0.500	3
4	710-0604A	Screw TT		6-Kant Schraube	5/16-18x0.625	8
5	710-1238	Hex Hd. Washer Screw		6-Kant Schraube	5/16-18x.875	2
6	710-1260A	Screw LD		Schraube	5/16-18x0.750	2
7	710-1681	Hex Hd. Screw		6-Kant Schraube	M8-1.25x20Lg	6
8	710-1691	Screw		6-Kant Schraube	M6-1x12.00	4
9	712-0431	Flange L-Nut		Sicherungsmutter	3/8-16	2
10	712-0691	Hex L-Nut		Sicherungsmutter	M6 DIN 985	4
11	712-0692	Hex L-Nut		Sicherungsmutter	M8 DIN 985	10
12	723-0444	Strap Battery 400		Batteriegurt		1
13	732-1034	Compression Spring		Druckfeder	39ODx105Lg	2
14	736-0222	Lock Washer		Zahnscheibe	1/4"	2
15	736-0331	Bell Washer		Tellerfeder	.390x1.13x.062	2
16	736-0498	Lock Washer		Federring	1/4	1
17	737-3007	Grease Alvania EP2		Fett		1
18	738-0143	Shoulder Screw		Schulter Schraube	3/8-16	2
19	738-0140	Shoulder Screw		Schulter Schraube		4
20	783-0349	Tray Battery 400		Batteriekasten		1
21	783-0726B	Brkt Pivot Support RH		Vorderachshalter rechts		1
22	783-0727A	Brkt Pivot Support LH		Vorderachshalter links		1
23	783-0728	Brkt Pivot Bar		Vorderachsträger		1
24	783-1317	Frame RR Left		Rahmen hinten links		1
25	783-1318	Frame RR Right		Rahmen hinten rechts		1
26	783-1410	Plate Top		Abdeckplatte hinten		1
27	725-1426	Solenoid		Magnetschalter	12V , 100A	1
28	725-1802	Signal Dvice		Signalgeber		1
29	725-2057	Battery , Dry		Batterie	U1 ,245 CCA	1
30	750-04016	Drain Hose		Schlauch ,Drain.		1
31	710-3015	Screw		Schraube	1/4-20 x .75 lg.	2
32	712-0271	Hex.Nut		6-kt.Mutter	1/4-20	2
33	751-0818	Fuel Tank , 2 Gal	Reservoir	Tank , 2.0 Gallone		1
34	751-0603	Fuel Cap	Capuchon	Tankdeckel		1
35	710-0604A	Screw TT	Vis	6-Kant Schraube	5/16-18x0.625	4

500er Serie

813-01146

Dash, 8/9-Style man.PTO w/Cruise

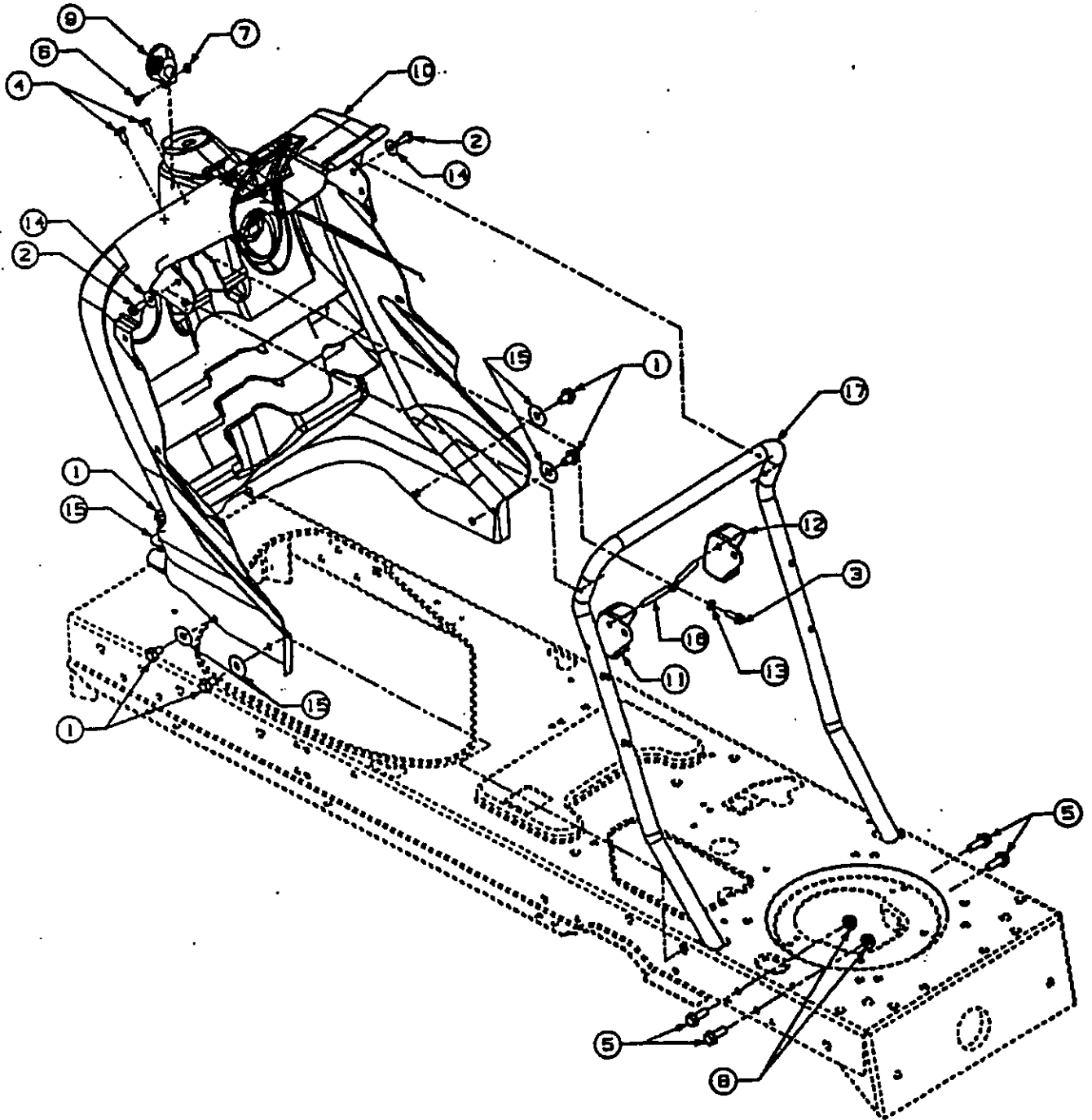

E3-01612A

500er Serie

Dash ,8 / 9 Style man.PTO w/Cruise

Ref	Order Nr	Description	Désignation	Bezeichnung	Standard	Qty
1	710-0604A	Screw TT		6-Kant Schraube	5/16-18x0.625	
2	710-0642	Screw TT		6-Kant Schraube	1/4-20x0.750	
3	710-0895	Screw HL		6-Kant Schraube	1/4-15x0.750	
4	710-1017	Screw AB		Schraube	1/4-14x0.625	
5	710-1238	Hex Wash. Hd. Screw		6-Kant Schraube	5/16-18x.875	
6	710-3217	Mach. Screw		Rundkopfschraube	8-32x0.375	
7	712-0142	Nut		Mutter	8-32	
8	712-3004A	Flange L-Nut		Mutter	5/16-18	
9	731-1857	Knob		Griff		
10	731-2122C	Panel Dash		Armaturenkonsole		
11	731-2226	Lever Dash Cruise		Griff Tempomat		
12	731-2227	Lever Dash Brake		Griff Parkbremse		
13	736-0142	Fl. Washer		Scheibe	.281x.50x.063	
14	736-0270	Bell Washer		Tellerfeder	.285x1.00x.063	
15	736-3078	Fl. Washer		Scheibe	.349x1.00x.063	
16	747-1198	Rod Lever Bent		Aushebestange		
17	749-1087A	Tube Dash Supt.		Halteboigel Armaturenbrett		

500er Serie

813-01010

Dash, 4-Style man.PTO

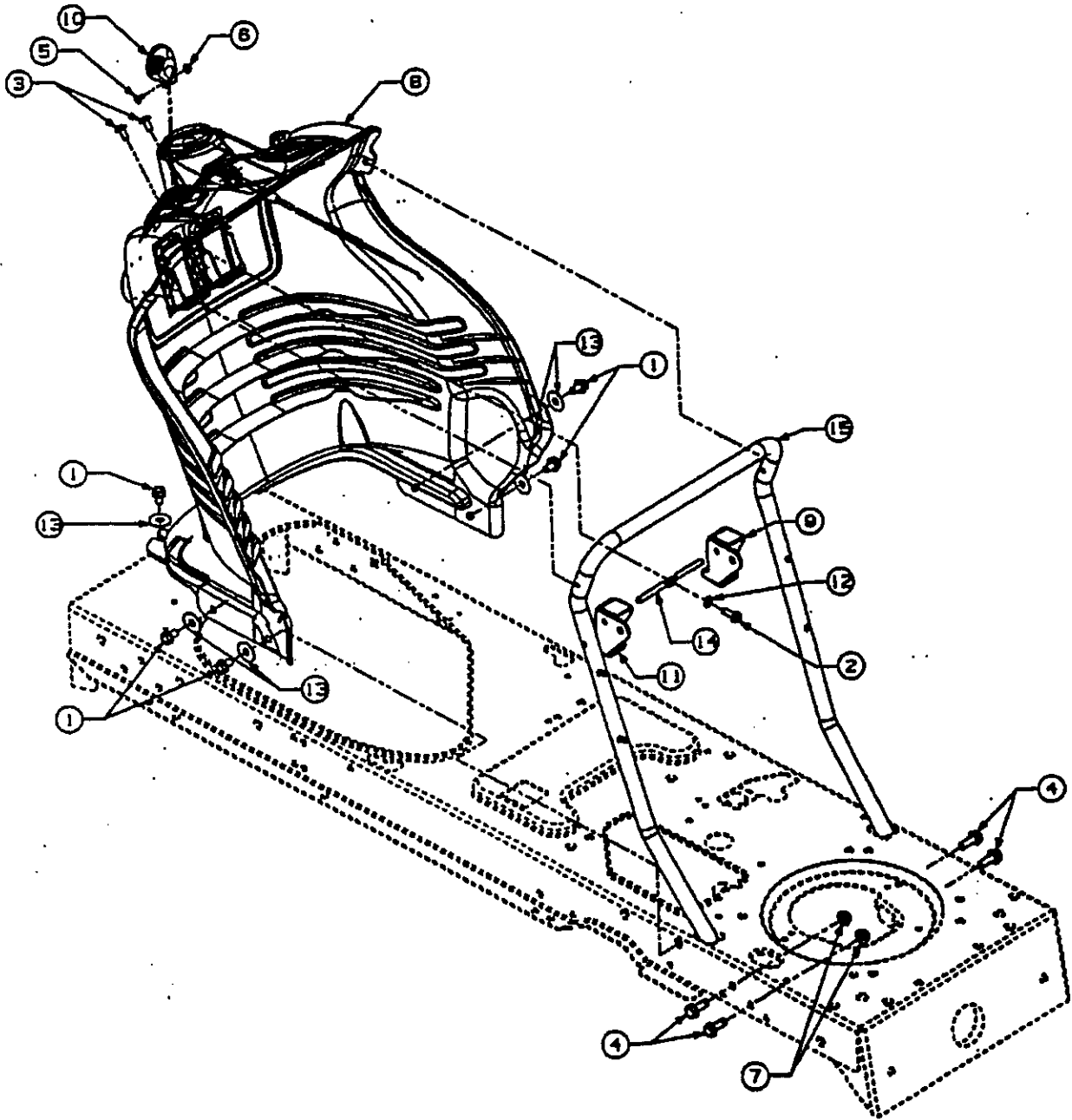

E3-01610A

500er Serie

Dash ,4-Style man.PTO

Ref	Order Nr	Description	Désignation	Bezeichnung	Standard	Qty
1	710-0604A	Screw TT		6-Kant Schraube	5/16-18x0.625	
2	710-0895	Screw HL		6-Kant Schraube	1/4-15x0.750	
3	710-1017	Screw AB		Schraube	1/4-15x0.625	
4	710-1238	HH Screw		6-Kant Schraube	5/16-18x.875	
5	710-3217	Screw Mach		Rundkopfschraube	8-32x0.375	
6	712-0142	Nut		Mutter	8-32	
7	712-3004A	Flange L-Nut		Mutter	5/16-18	
8	731-0069C	Panel Dash		Armaturenkonsole		
9	731-0072	Lever Dash Brake		Griff-Parkbremse		
10	731-1857	Knob		Griff		
11	731-2106	Lever Dash Cruise		Cruise Schalter		
12	736-0142	Fl. Washer		Scheibe	.281x.50x.063	
13	738-3078	Fl. Washer		Scheibe	.349x1.00x0.63	
14	747-1155	Rod Lever Brake		Haltestange f. Bremschalt.		
15	749-1087A	Tube Dash Support		Haltebügel Armaturenbrett		